



# aquatherm black system

**Heating and cooling system**

for ceiling, wall and other applications



**aquatherm**

state of the pipe





## CONTENTS

<b>Features</b>	6	<b>Assembly, Installation and Test record</b>	71
› Heating and cooling for ceilings and walls	6-14	› Assembly and starting	71
› Product information		› Starting	
› Advantages		› Flushing, filling and venting	
› Material		› Leak test	
› Technical data		› Functional heating	
<b>Principles</b>	15	› Test records	72-74
› Connection method	15-17	› Functional test for wet installed surface heating- and/or surface-heating and cooling systems (for wall and ceiling)	
› Part 1: fusion		› Functional test for dry installed surface heating- and cooling systems	
› Connection method	18-19	› Leak test of surface heatings and surface coolings	
› Part 2: push-fit connection			
› aquatherm black system technology	20-24	<b>Products</b>	75
› System review		› Products	75
› Comfort		<b>Projects and Notes</b>	88
› aquatherm black system wall/ceiling		› Examples:	88-92
› Visual performance heating and cooling (metal ceiling panel)		› SHB, Munich, Germany	
› Visual performance heating and cooling (plaster wall)		› Mennekes, Lennestadt, Germany	
› Surface temperatures		› Hanse Hotel, Attendorn, Germany	
› Surface considerations		› AXA, Antwerpen, Belgium	
› Conduits and cables		› Sky Office, Zagreb, Croatia	
› Expansion joint		› Notes	93
› Connection systems & performance values	25-54		
› Plasterboard ceiling with metal substructure			
› Plasterboard ceiling with wooden substructure in vaulted roofs			
› Metal ceiling panel as clip-in system			
› Metal ceiling panel as strip grid system			
› Freely floating ceiling			
› Plaster ceiling			
› Dry constructed wall with gypsum plaster board			
› Dry constructed wall with cement board			
› Plastered wall			
› Further fields of application			
› Control method	55-65		
<b>Planning</b>	66		
› Planning and design „heating/cooling“	66		
› Planning and design „diagrams“	68-70		
› Graph of pressure drop			
› Maximum surface per each cooling circuit			

# SERVICE

## TECHNICAL HOTLINE +49 (0)2722 950 200

info@aquatherm.de www.aquatherm.de

**Parent plant Attendorn**  
**aquatherm GmbH**  
Biggen 5  
D-57439 Attendorn  
Phone: +49 (0)2722 950 0  
Fax: +49 (0)2722 950 100

**Subsidiary Radeberg**  
**aquatherm GmbH**  
Wilhelm-Rönsch-Str. 4  
D-01454 Radeberg  
Phone: +49 (0) 3528 4362-0  
Fax: +49 (0) 3528 4362-30



### Field staff

In addition to the regular training service at Attendorn and Radeberg aquatherm field staff are available to assist customers, on site, throughout Germany.



### Training service

In addition to training service through the merchant network aquatherm offers its customers training, free of charge, at its training centres at Attendorn and Radeberg.

### Fair

aquatherm is represented on all important fairs relevant for the sanitary and heating sector in Germany or abroad with its own exhibition booth. For more information regarding fairs near to you, please visit internet page: [www.aquatherm.de](http://www.aquatherm.de).

## CERTIFICATIONS IN ACCORDANCE WITH ISO 9001, 14001 & 50001

Since 1996 aquatherm has been meeting the requirements of the certifiable quality management system according to DIN ISO 9001. The 2012 TÜV certificate was extended by the environmental management system according to ISO 14001 and currently by the energy management system according to ISO 50001.

This success is a great contribution and represents a further step to strengthen our competitive position and to meet the high requirements and the responsibility for our customers, partners and the environment.



Management System  
ISO 9001:2008  
ISO 14001:2004  
ISO 50001:2011  
www.tuv.com  
ID 0091005348



### Laboratory

The aquatherm laboratory: from the testing of granulate through to the finished product the customer can be assured of only the highest quality products.



### Software-Service

The aquatherm-software service provides Datanorm-files, an independent graphical program (liNear), and the appropriate training.



### Miscellaneous

Different aquatherm-CD's, prospects, catalogues, poster, leaflets, mailings,calen-dars, a.s.m. are investigated and produced from the internal advertising department. All information regarding the company, the technology, the products, the various trainings and fairs as well as all catalogues in pdf-form can be called and downloaded from the aquatherm - website: [www.aquat-herm.de](http://www.aquat-herm.de).

# SERVICE



## HEATING AND COOLING WITH aquatherm black system

An individual's physical well-being directly depends on the basic environmental conditions of the surroundings. Working efficiency varies according to temperature with every cooling degree.

Incorrect controlled room temperature, noise interference or draught are responsible for inefficient room conditions and therefore unsatisfactory performances. In offices, commercial premises, meeting rooms, etc., aquatherm pipe grids have become increasingly more popular for heating and cooling of ceilings and walls.

The ingenious aquatherm black system delivers pleasant room conditions without noise and forced air movement. With this technology cooling or heating is simply controllable.

Automatic designed change-over of heated or chilled water completes this system; allowing for individual room control within a building management system.

aquatherm black system – due to its slim construction it fits tight below the plaster layer or behind the plaster board. Construction thickness including manifolds, mounting rail and connections amounts to only 24.5 mm. The pipe grids have rectangular manifolds, which can be interlinked mutually.

This allows an easy connection e.g. according to the reverse return principle (Tichelmann). The water volume for the required thermal output is distributed via square pipes (12 mm/25 m pipe per m<sup>2</sup>) within the grids.

The velocity of flow and the pressure drop are minimized.

The aquatherm black system can be installed on metal panels of suspended ceilings and on plaster boards. Even the embedding in plaster layer or the installation in C-studs with plaster boards is not a problem.

The low weight of only 2.5 kg/m<sup>2</sup> (incl. water filling) does not affect the design of the ceiling element construction. The ceiling elements should include minimum 30 mm fibre glass insulation. Depending on their design, the pipe grids are connected by means of thermal welding or by pushfit couplings, respectively connected to the cooling- and heating water circuits.

### Advantages:

- › No draughts
- › Noiseless
- › Dust reduction
- › Simple control technique
- › Thermal properties of the building are enhanced
- › System extendable
- › Quick installation thanks to high degree of prefabrication
- › Even temperature distribution
- › Safe connection techniques by thermal fusion/Pushfit connection for ceiling elements
- › Oxygen barrier
- › Minimal construction thickness
- › Greater architectural design freedom
- › Energy saving
- › Suitable as plaster base for ceiling suspension

The effect of the aquatherm black system is to heat or cool the surface of wall or ceiling where it is installed behind by a few degrees below or above the ambient temperature. By radiation exchange with the surfaces, temperatures of the room and furnishings change. The total power is achieved by  $\frac{2}{3}$  radiation and  $\frac{1}{3}$  convection. The heat transfer rate is determined by the difference between ambient temperature and average surface temperature – high difference – high heat transfer.

As the size of the aquatherm black system matches exactly the size of the metal panels, any inactive ceiling surfaces can be combined. This is especially interesting as in most cases not all ceiling surfaces must be covered with grids. Active and inactive surfaces can be combined without visible differences. The re-fitting or future installation with the aquatherm black system is feasible.

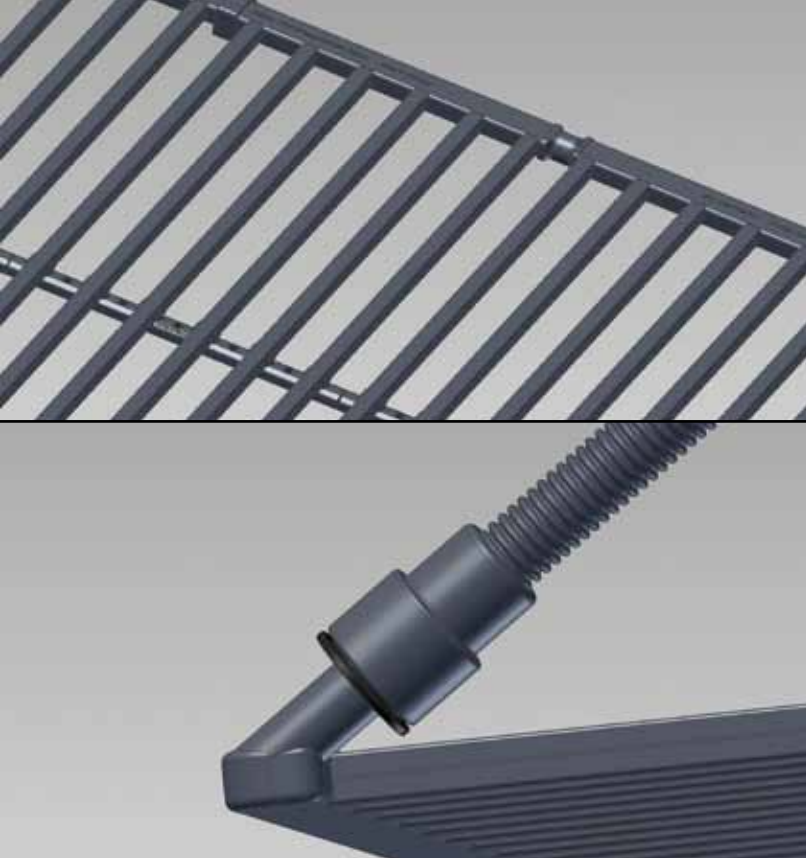

**HEATING AND COOLING GRIDS** oxygen tight acc. to DIN 4726

**Material:**

aquatherm pipe grids are exclusively made from fusiolen® PP-R. Its extreme temperature stability is a major property of the product. The physical properties specially match the requirements of the heating and cooling sector.

The exceptionally good welding properties and the fusion, in an homogeneous unit, offer a maximum in security and durability. fusiolen® PP-R also offers high temperature and compressive strength.

A permanent operating temperature of 70 °C is no problem. Normally the aquatherm black system operates at substantially lower temperatures than conventional heating systems.

Hence, the actual material stressing is much lower. Furthermore fusiolen® offers an excellent resistance against various aggressive chemicals.

In conjunction with the aquatherm blue pipe system (also made from fusiolen® PP-R for climate, heating and industrial technology), aquatherm offers a complete solution from the heating and cooling source.

Material	fusiolen® PP-R
Manifold/Collector in square design	24/14 mm
Grid pipes in square design	12/12 mm
Center distance of grid pipes	40 mm
Lengths	400-1000 mm (in 100 mm-steps) 1000-2000 mm (in 200 mm-steps) 2000-5000 mm (in 250 mm-steps) <b>special sizes on request!</b>
Width	240 - 1000 mm (in 40 mm-steps)
Area of exchange	1,0 m <sup>2</sup> /m <sup>2</sup>
Volume	1,2 ltr./m <sup>2</sup>
Weigth (incl. water)	2,5 kg/m <sup>2</sup>
Max. heating water temperature	70°C
Colour	anthracite

Allowed permanent operating pressure	
4 bar	at max. 70°C
6 bar	from -20°C up to max. 40°C

Differing working conditions on demand

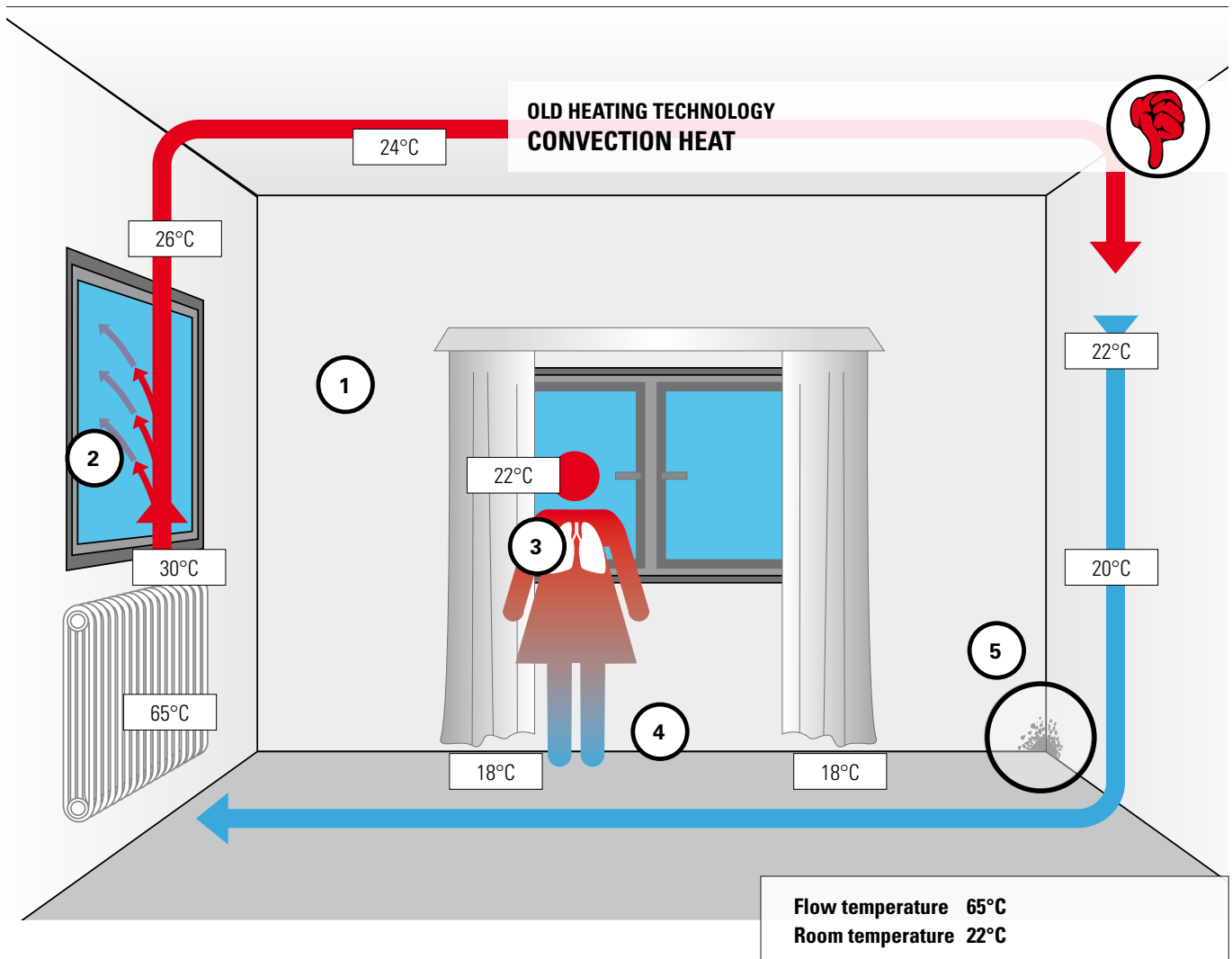

### THE CONVECTION HEATING WITH RADIATOR

- ① **Energy loss 1:**  
A high air temperature of at least 22°C is required to heat a room with air. Air is a bad heat carrier; therefore the energy costs are high.
- ② **Energy loss 2:**  
Even premium quality windows are the weak point of a house-insulation and result in high energy losses. The air heats up the glass and the energy leaks when venting.
- ③ **Health at risk:**  
The air movement (warm air rises) kills the sense of well-being, too, since asthmatic and allergic persons have a primary problem with raising dust. This dust mixes with our breathing air and can lead to enormous burdens of the organism. An increase of the room temperature requires a reduction of the air humidity. Mucous membranes will dry out. The natural filtration system (nose) will be affected.
- ④ **Discomfort:**  
Feet remain cold, as warm air rises up and is mainly in the upper area of a room. By that a feeling of discomfort is developed. The heating is adjusted to a higher level. The above effects will be increased.
- ⑤ **Formation of mould:**  
Cold air strokes the wall, water condenses and creates the culture medium for the formation of mould.



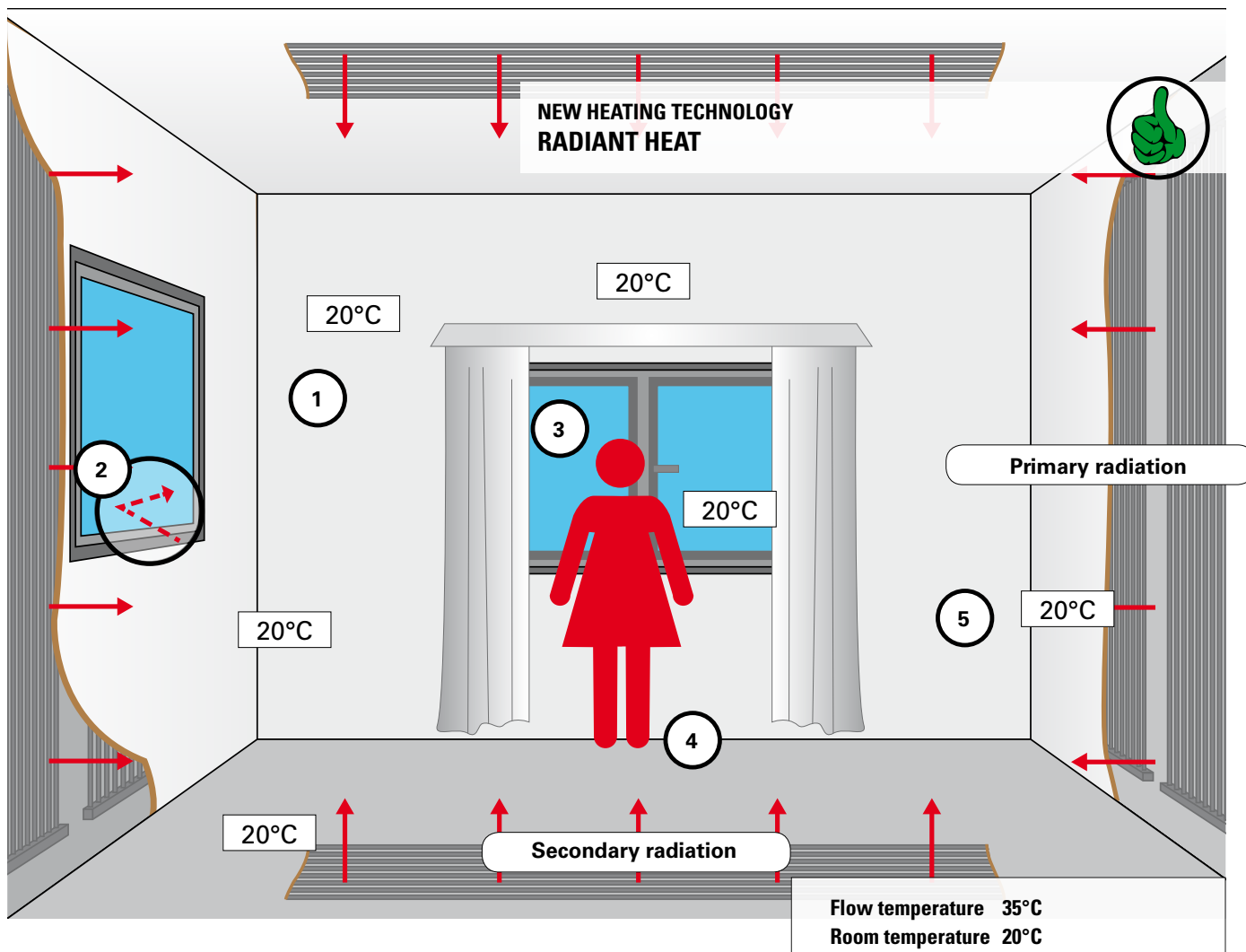

**THE RADIANT HEATING WITH THE NEW AQUATHERM BLACK SYSTEM**

- ① Energy saving 1:**  
 Comparable to the sun, the radiant heating first of all heats the solid and liquid materials in a room. Walls, ceilings and floors are constantly heated and the room temperature only in the second step. However, a high air temperature is not required for radiant heatings. An air temperature of 20°C is completely sufficient and provides a comfortable sense of well-being.
- ② Energy saving 2:**  
 There is no loss through the window. Heat radiation is reflected by glass and given back to the room.
- ③ Energy saving 3:**  
 The room temperature is low. Thus you will not have any high energy loss, even when airing. The low air temperature creates a natural and pleasant climate.
- ④ Comfort:**  
 In case of radiant heat, there are no differences in temperature of the room air, like with convection heatings. The head remains cool and the feet warm.
- ⑤ Dry walls:**  
 Since the walls are directly heated, there is no condensation and consequently no formation of mould.

**RULE OF THUMB:**  
**REDUCTION OF ROOM TEMPERATURE BY 1°C = 6 % ENERGY SAVING**  
**SURFACE TO BE OCCUPIED = 60-100 % OF THE BUILDING AREA, DEPENDING ON THE BUILDING STRUCTURE**

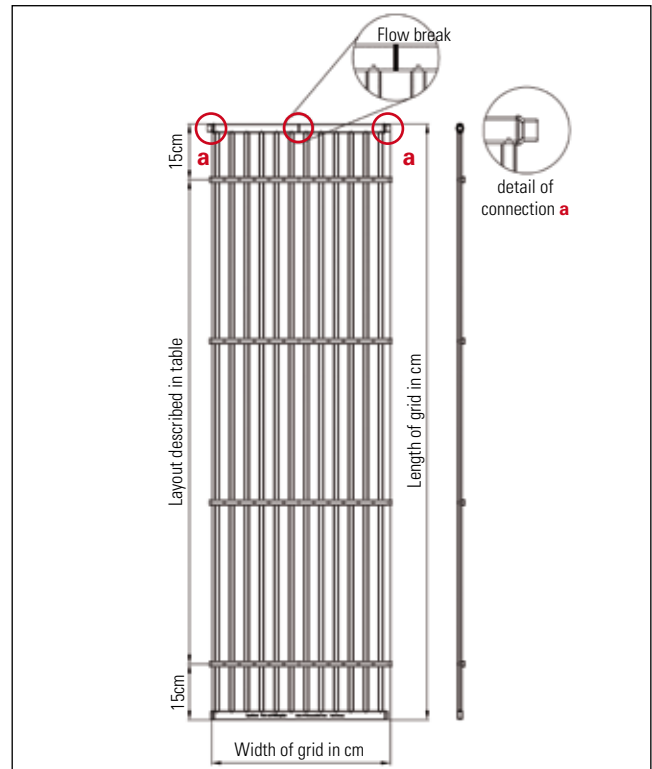
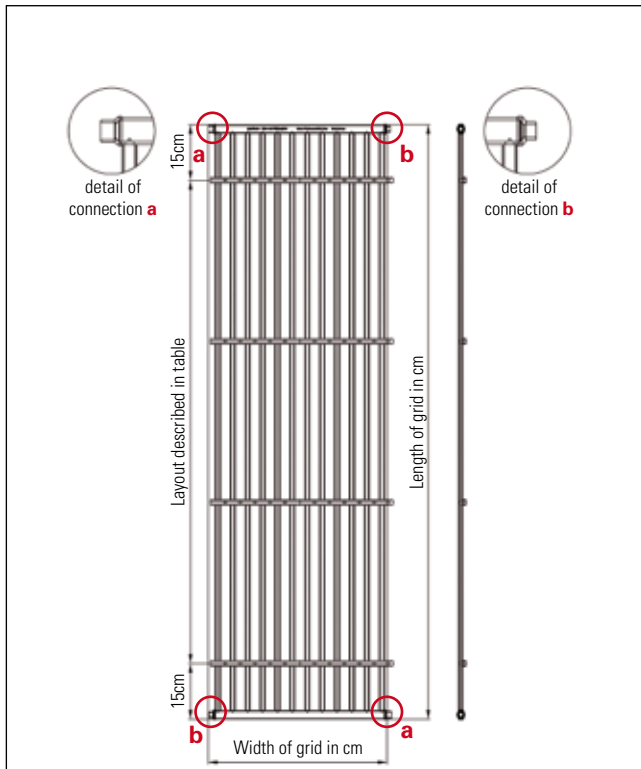

**AQUATHERM BLACK SYSTEM - HEATING AND COOLING GRIDS**

**Connection type 50 = side by side welded connections**

**Description**

The aquatherm black system grid with the connection type 50 is a grid with welded connections between the grids. The welded connections are placed on four sides as side by side outlet with welding socket (female end) 16 mm (a) top left and lower right respectively aligned for welding to welding nozzle (male end) 16 mm (b) top right and lower left.

Fixing rails at the grid (quantity described in table) are for mounting and grid stability. Attached wall brackets (two pieces up to a grid width of 68 cm, four pieces from 68 cm) can be installed at the manifold, if required.

**Application**

The aquatherm black system-grid with the connection type 50 is mainly applied for the installation in plaster walls and ceilings. But it also can be used in dry wall constructed ceilings in vaulted rooms or in dry constructed walls. Detailed information about the installation and connection are further described in each system description.

**Connection type 64 = welded connection female left, right**

**Description**

The aquatherm black system grid with the connection type 64 is a grid with welded connections between the grids. The welded connections are placed side by side with welding socket 16 mm (a) left and welding nozzle (male end) 16 mm (b) right. In the center the manifold/collector is a flow break made by the welding-in of a blind cap in the manifold/collector. This results in the one-sided connection of the grids to each other.

Fixing rails at the grid (quantity described in table) are for mounting and grid stability. Attached wall brackets (two pieces up to a grid width of 68 cm, four pieces from 68 cm) can be installed at the manifold, if required.

**Application**

The aquatherm black system-grid with the connection type 64 is mainly applied for the installation in plaster walls and ceilings. But it also can be used in dry wall constructed ceilings in vaulted rooms or in dry constructed walls. Detailed information about the installation and connection are further described in each system description.

Length of grids	Number of fixing rails
up to 140 cm	2
up to 180 cm	3
up to 225 cm	4
up to 275 cm	5
up to 325 cm	6
up to 375 cm	7
up to 425 cm	8
up to 475 cm	9
up to 500 cm	10

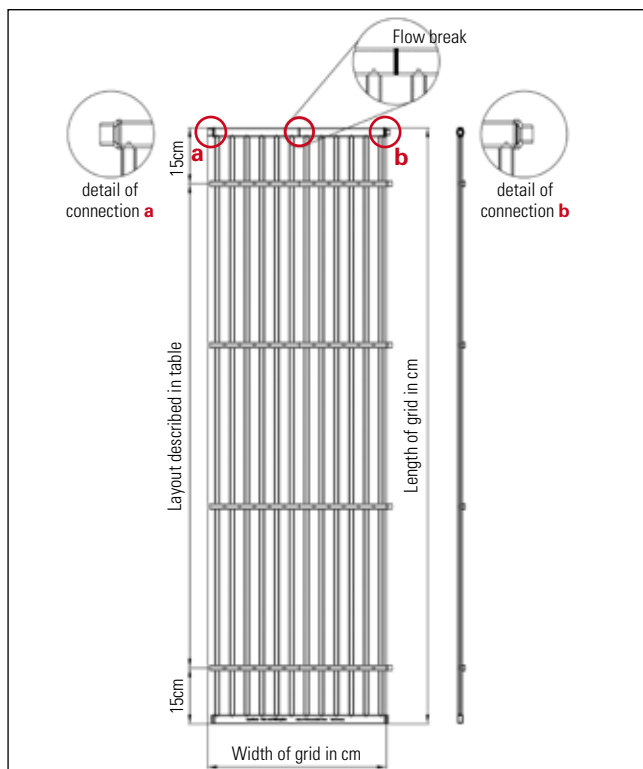

**Connection type 65 = welded connection female, left  
welded connection male, right**

**Description**

The aquatherm black system grid with the connection type 65 is a grid with welded connections. The welded connections are placed side by side as welded connection female 16 mm (a) left and welded connection male 16 mm (b) right. Centrally arranged between both connections in the distributor/collector is the flow interruption. This is done by welding a blind cap in the distributor/collector and provides the one-sided connection of the grids among each other.

Furthermore, there are mounting rails at the grid (number see table), which are used to fix and shape stability. Enclosed wall brackets (up to a grid width of 68 cm: two pieces; from 68 cm: four pieces) can be attached to the distributor/collector when needed

**Application**

The aquatherm black system grid with the connection type 65 is used primarily for the installation in plaster walls and ceilings. The exact installation and connection situation can be found in the individual systems.

Length of grids	Number of fixing rails
up to 140 cm	2
up to 250 cm	3
up to 350 cm	4
up to 450 cm	5
up to 500 cm	6

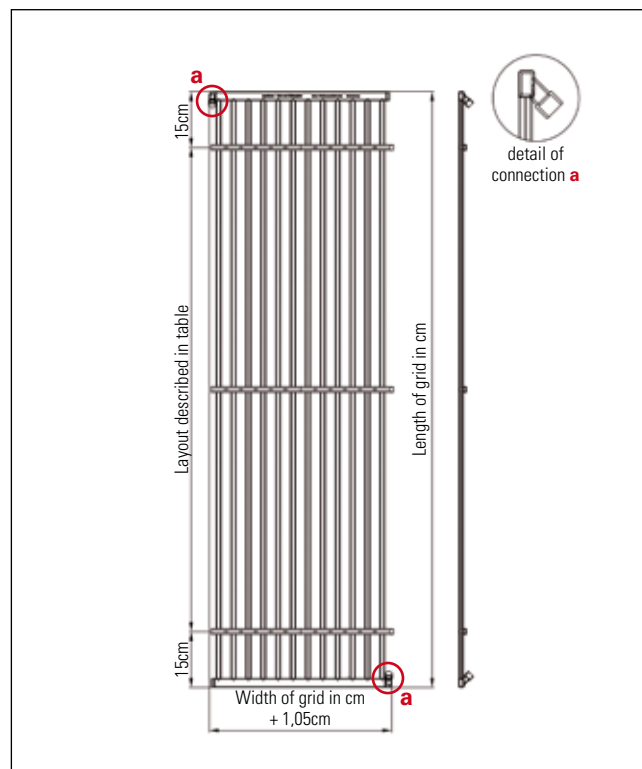

**Connection type 59 = welded connection 45°  
top left, lower right**

**Description**

The aquatherm black system grid with the connection type 59 is a grid with welded connections. The welded connections are placed two-sided and are at a 45° angle with welding socket (female) 16 mm (a) top left and lower right. Fixing rails at the grid (quantity described in table) are for mounting and grid stability.

**Application**

The aquatherm black system-grid with the connection type 59 is mainly applied for the installation in dry wall constructed ceilings with metal sub-structure. Detailed information about the installation and connection are further described in each system description.

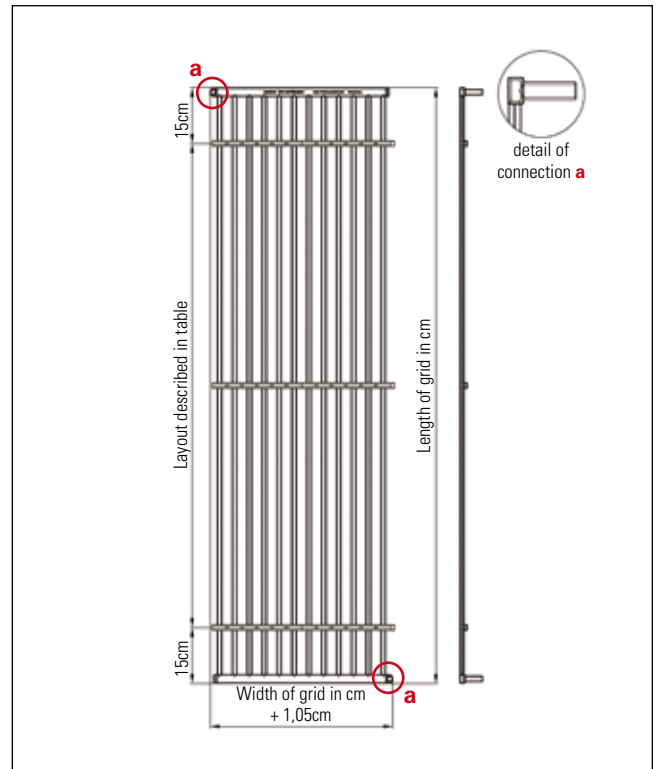
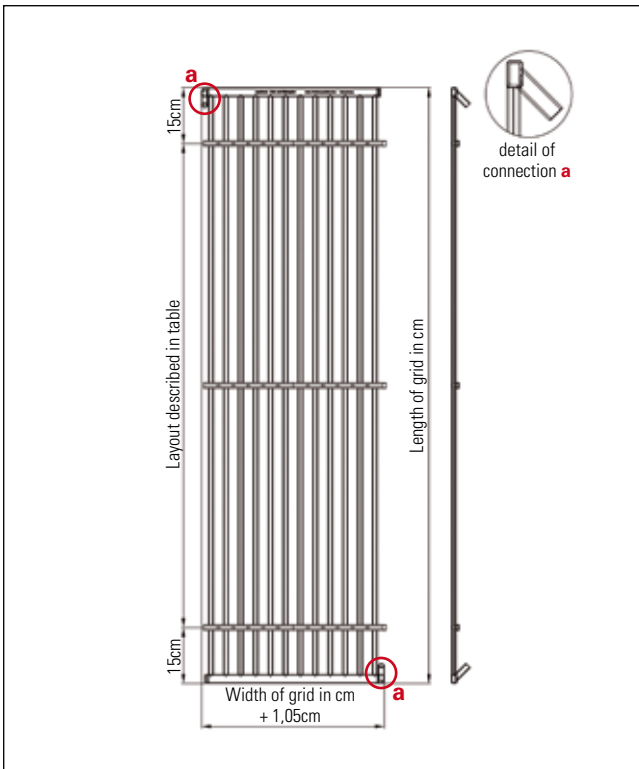

**AQUATHERM BLACK SYSTEM - HEATING AND COOLING GRIDS**

**Connection type 51 = plug connection 45°  
top left, lower right**

**Description**

The aquatherm black system grid with the connection type 51 is a grid with plug connections. The plug connections are placed two-sided and are at a 45° angle with plug socket 16 mm (a) top left and lower right. Fixing rails at the grid (quantity described in table) are for mounting and grid stability.

**Application**

The aquatherm black system-grid with the connection type 51 is mainly applied for the installation in dry wall constructed ceilings with metal substructure or metal ceiling panels. Detailed information about the installation and connection are further described in each system description.

**Connection type 52 = Plug connection 90°  
top left, lower right**

**Description**

The aquatherm black system grid with the connection type 52 is a grid with plug connections. The plug connections are placed side by side and are at a 90° angle with plug socket 16 mm (a) top left and lower right. Fixing rails at the grid (quantity described in table) are for mounting and grid stability.

**Application**

The aquatherm black system-grid with the connection type 52 is mainly applied for the installation in metal ceiling panels, but it can also be used in dry constructed ceilings with metal substructure. Detailed information about the installation and connection are further described in each system description.

Length of grids	Number of fixing rails
up to 140 cm	2
up to 250 cm	3
up to 350 cm	4
up to 450 cm	5
up to 500 cm	6

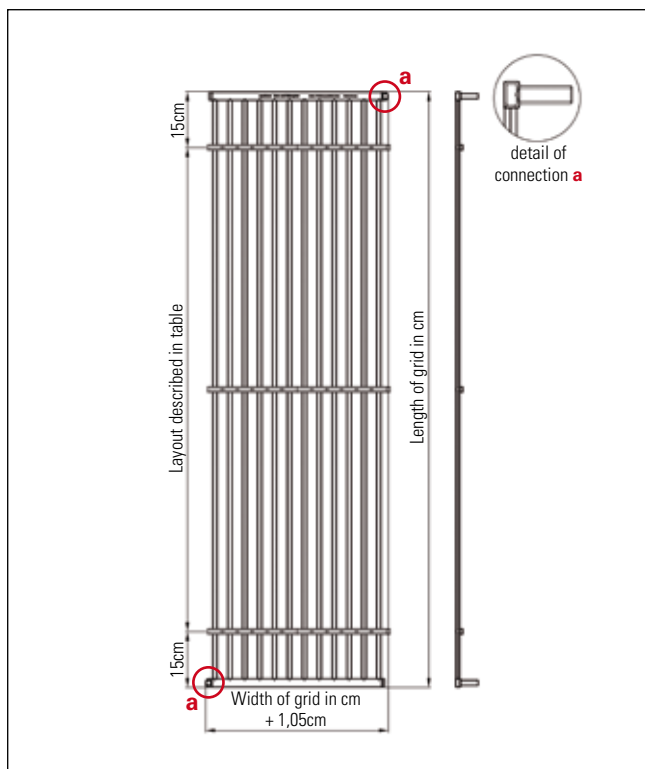

**Connection type 53 = Plug connection 90°  
top right, lower left**

**Description**

The aquatherm black system grid with the connection type 53 is a grid with plug connections. The plug connections are placed side by side and are at a 90° angle with plug socket 16 mm (a) top right and lower left. Fixing rails at the grid (quantity described in table) are for mounting and grid stability.

**Application**

The aquatherm black system-grid with the connection type 53 is mainly applied for the installation in metal ceiling panels, but it can also be used in drywall ceilings with metal substructure. Detailed information about the installation and connection are further described in each system description.

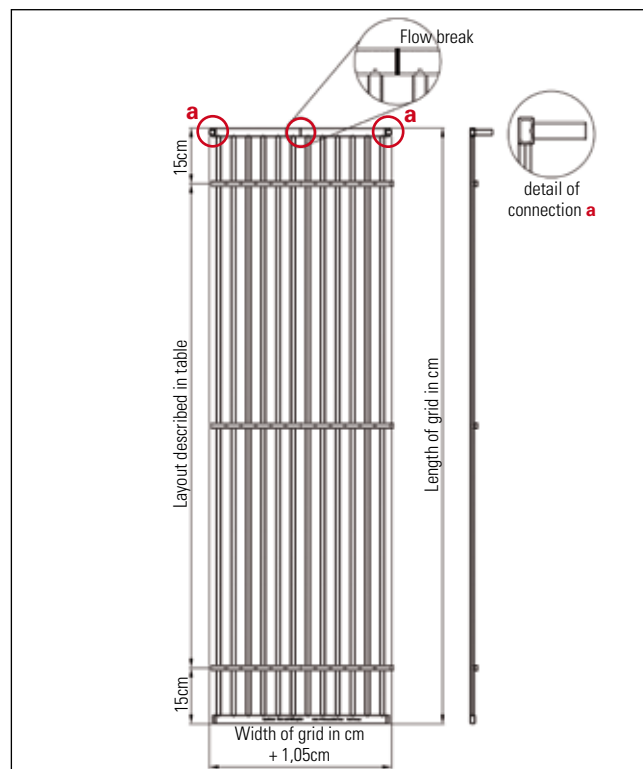

**Connection type 62 = plug connection 90°  
left, right**

**Description**

The aquatherm black system grid with the connection type 62 is a grid with plug connections. The plug connections are placed side by side and are at a 90° angle with plug socket 16 mm (a) right and left. In the center the manifold/collector is a flow break made by the welding-in of a blind cap in the manifold/collector. This results in the one-sided connection of the grids to each other. Fixing rails at the grid (quantity described in table) are for mounting and grid stability.

**Application**

The aquatherm black system-grid with the connection type 62 is mainly applied for the installation in metal ceiling panels and freely floating ceiling, but it can also be used in dry wall ceilings with metal substructure. Detailed information about the installation and connection are further described in each system description.

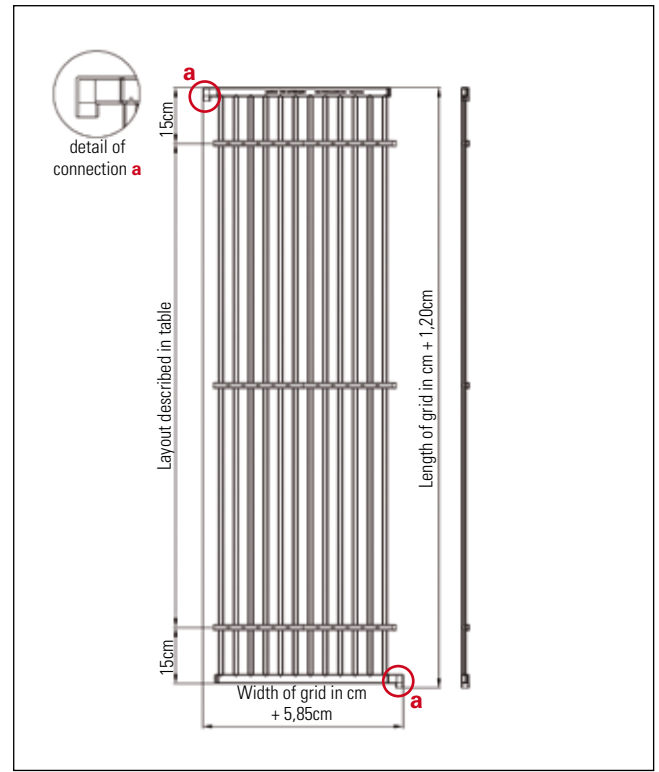
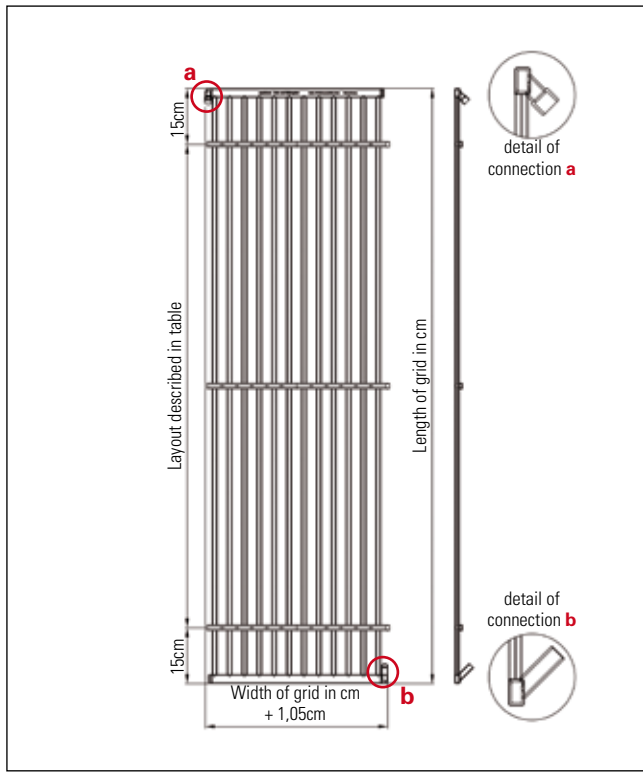

**Connection type 58 = welded connection 45° top left  
plug connection 45° lower right**

**Description**

The aquatherm black system grid with the connection type 58 is a grid with welded and plug connections. The welded connection is placed two-sided and is at a 45° angle with plug socket 16 mm (a) top left and the plug connection is placed one-sided as 45° angle with plug socket 16 mm (b) lower right. Fixing rails at the grid (quantity described in table) are for mounting and grid stability.

**Application**

The aquatherm black system-grid with the connection type 58 is mainly applied for the installation in metal ceiling panels, but it can also be used in dry wall ceilings with metal substructure. Detailed information about the installation and connection are further described in each system description.

**Connection type 56 = welded connection 90°  
top left, lower right**

**Description**

The aquatherm black system grid with the connection type 56 is a grid with weldable connecting elbows. The connecting elbows are placed two-sided with welding socket 16 mm (a) top left and lower right. Fixing rails at the grid (quantity described in table on page 12) are for mounting and grid stability.

**Application**

The aquatherm black system-grid with the connection type 56 is mounted on a cement board and is **only** applied for installation in a drywall. Detailed information about the installation and connection are further described in each system description.

**Aberrant composition of the article number**

The grids with connection type 56 are supplied mounted on a cement board. The numbers in the article number, aberrant from the remaining grids, in this case do not refer to the sizes of the grids, but to the connection of the internal piping and the length of the cement boards. The width of the cement boards is the same for all articles of the connection type 56 – it is 62,5 cm.

**56 62 200**

Connection type of the grids

Connection internal piping  
(62 = PP-R 16 mm, weldable)  
(63 = SHT-sliding sleeve technique)

Length of gypsum plaster board  
(050 = Length 50 cm)  
(100 = Length 100 cm)  
(200 = Length 200 cm)

The width of the cement board is always 62,5 cm

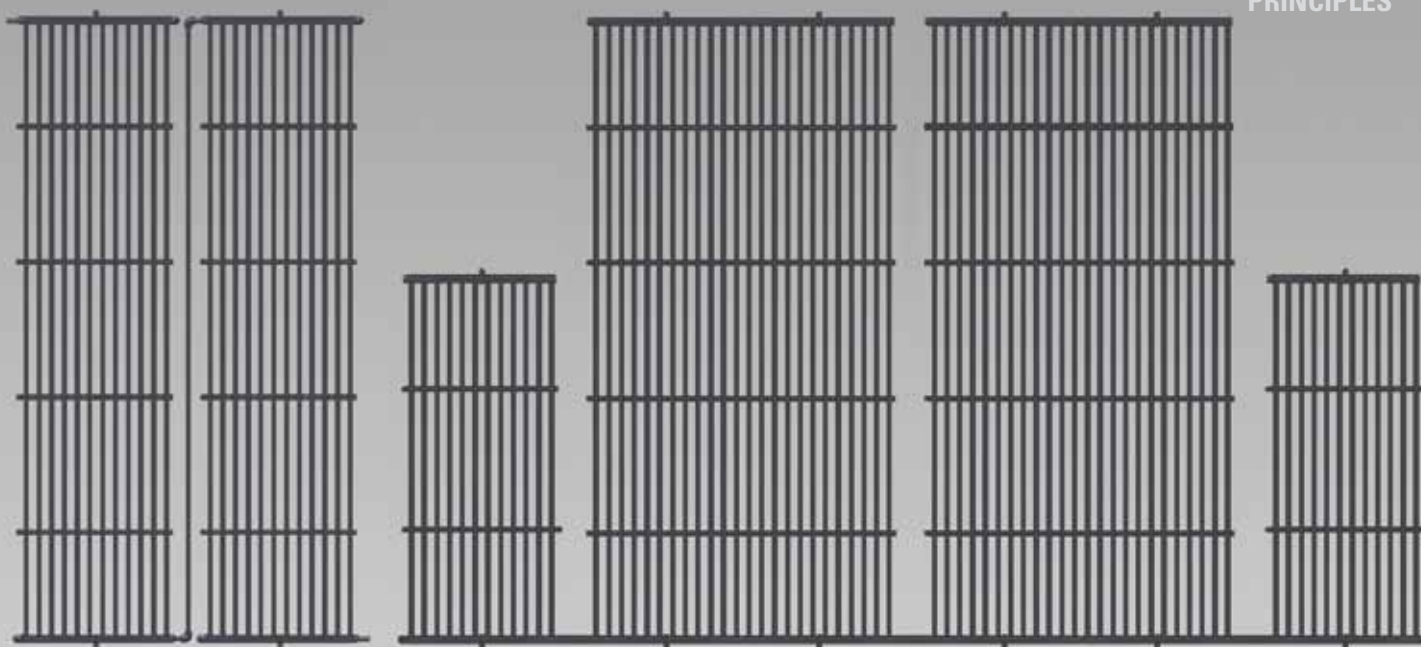

## CONNECTION METHOD PART 1: FUSION

The aquatherm black system is connected by "fusion".

Simply by heating up the joining elements the plastic melts and forms a permanent connection. The grids can be connected side by side as well as diagonally.

Due to the wide range of aquatherm green pipe fittings single connections as well as complete commercial sized installations, including manifolds, can be constructed.

Transition connections for the approved aquatherm grey pipe sliding sleeve technology complete the system.

Differing wall thicknesses of aquatherm green pipe fittings and aquatherm black system components require slightly different heating-up times. Due to the thicker wall thickness the aquatherm green pipe fittings should be pushed first on the welding tool and then the aquatherm black system PP-grid pipe is heated up.

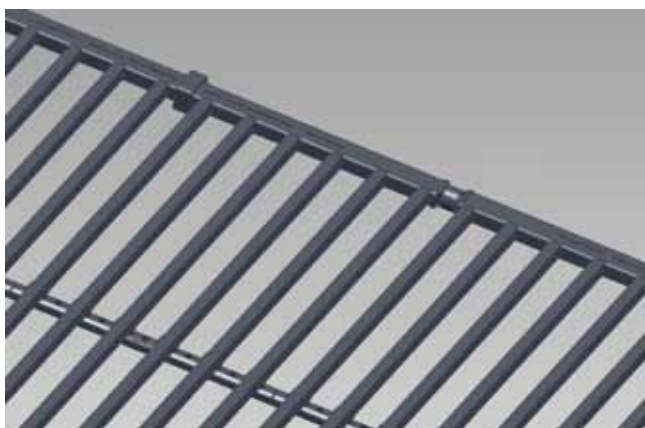

## FUSION OF THE AQUATHERM BLACK SYSTEM

side by side:

In side by side connection grids of the same height are connected to grid pairs.

**1.**  
Mounted welding device and tools (16 mm); Control of temperature



**2.**  
aquatherm black system is equipped with male/female connections for side by side fusion



**3.**  
Push the female connection of the first grid on the (socket) heating tool and at the same time the male connection of the second grid in the (spigot) heating tool



**4.**  
After the required heating period of 5 sec., remove the elements from the tools and directly push together (welding depth 13 mm)





## CONNECTION METHOD PART 1: FUSION

Fusion of the aquatherm black system with one-sided resp. diagonal connection:

For one-sided resp. diagonal connection grid pairs are connected to heating-cooling circuits.

Even grids of different height are connectable.

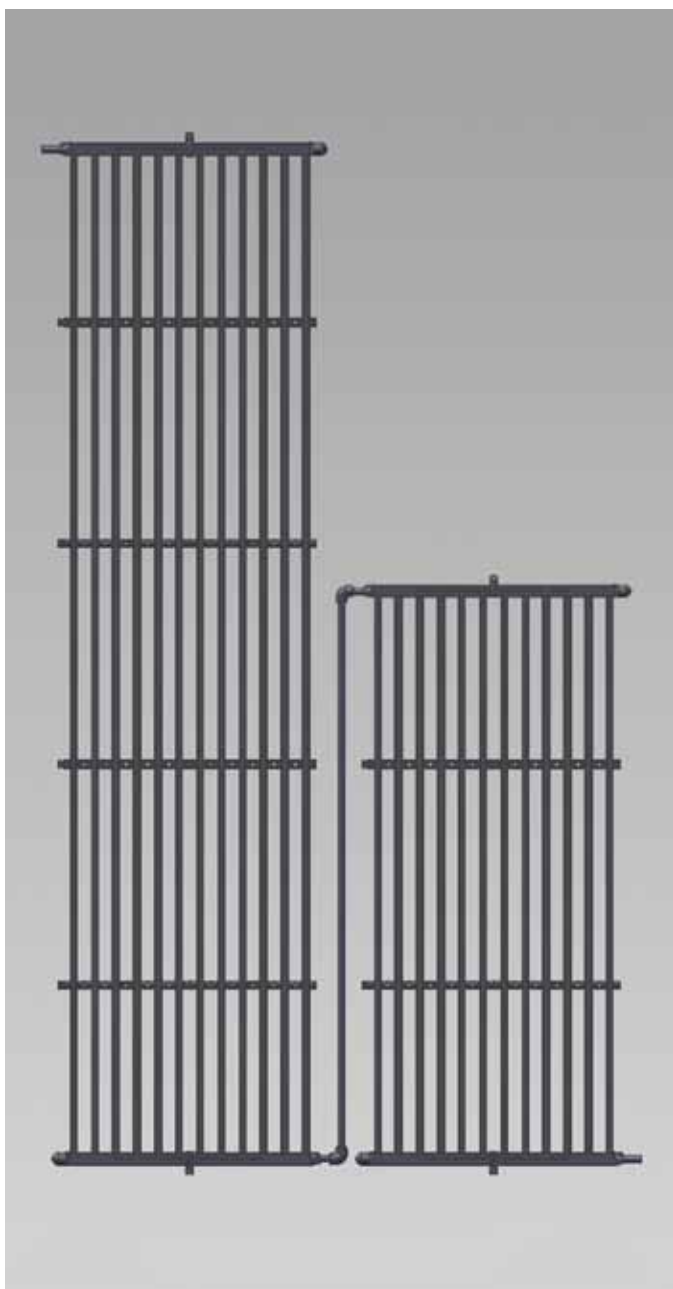

Fusion of pipe pieces

## CONNECTION METHOD PART 2: PUSH-FIT CONNECTION

The aquatherm black system in suspended ceilings is connected quickly and safely with pushfit-connectors.

The aquatherm black system grid has 16 mm plug-in connections, on which the push-fit connection is inserted as far as possible.

The holder/ring inside, is equipped with stainless steel teeth, keeping the connection firmly in the joint. The two integrated O-rings guarantee a completely sealed and secure connection.

The holding ring and the O-ring are kept in position by a brass locking ring.

### Various connections are available for joining aquatherm black system with the pipe systems

Corrugated connecting pipe with various connections

- 1) push-fit connection
- 2) sliding sleeve connection
- 3) fusion
- 4) transition with internal thread
- 5) transition with external thread

\* (fittings of the aquatherm green pipe-system)

## CONNECTION METHOD PART 2: PUSH-FIT CONNECTION

### Attaching of the plug-adapter

The adapter, including the (red) safety-clip, is pushed on the male end as far as possible. Consider, that the holder (black ring) does not cant at the male end. To visually confirm the plug-in depth there is a marking (transition from smooth to rough surface) at the male end. If the plug-in depth is correct, the smooth surface of the male end will not be visible.

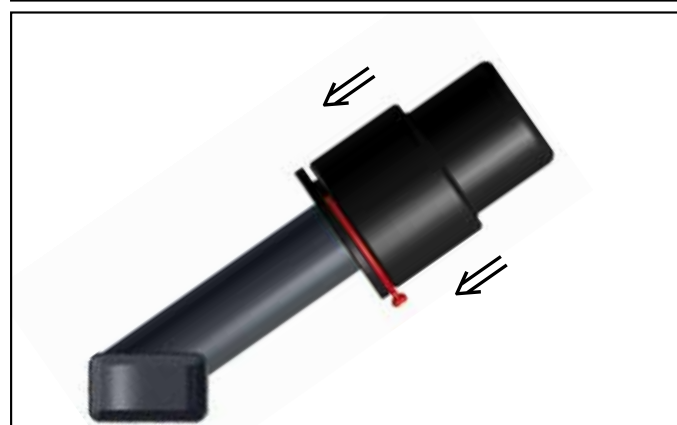
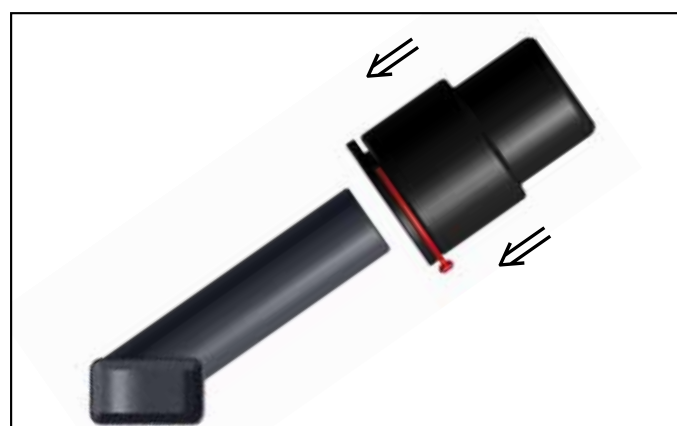

### Removal of the plug-adapter

Before removing the plug adapter from the male end, ensure that the system is unpressurized. Remove the safety-clip. Grasp the plug adapter with your hand and compress the holder (black ring). That enlarges the opening of the inner holding ring and the adapter can be pulled off the male end.

The connection can be reused.

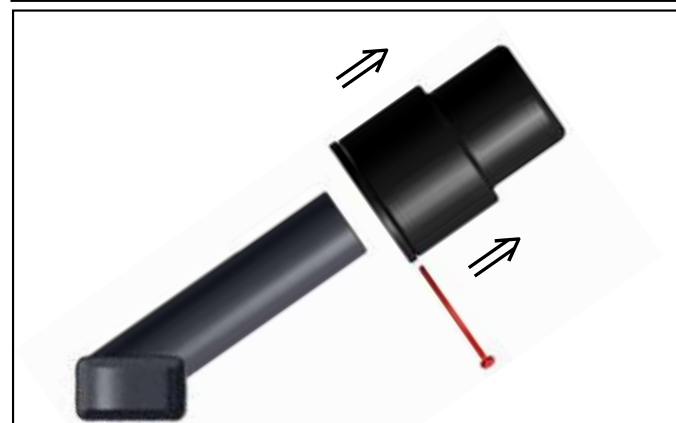
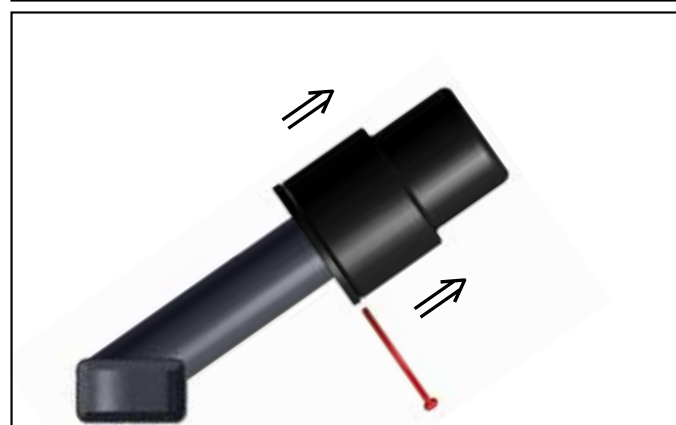
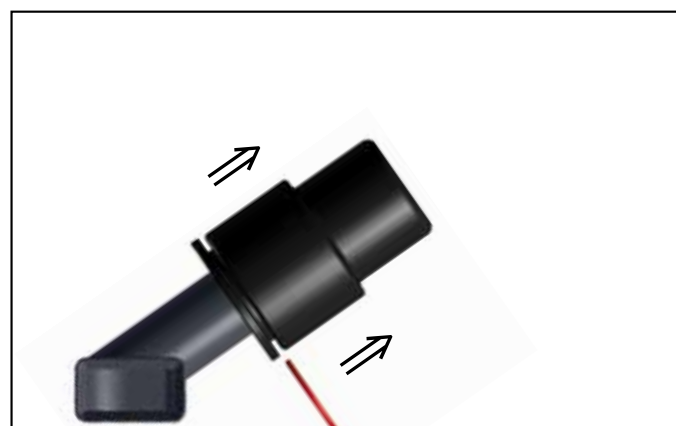

## SYSTEM TECHNIQUE AQUATHERM BLACK SYSTEM

### System review

The concept of the aquatherm black system is for the comfort of an occupied area: thermally well-balanced zones are created.

The principle of the aquatherm black system technology is gentle radiant heat from large surfaces delivering comfort and warmth to the occupants of a room. Since the heating surfaces are relatively large the surface temperature can be kept low reducing air movement. Radiant heat is felt directly, this is one advantage over small hot radiators that create high convectional currents warming the air before the occupants.

Since the system has a low flow temperature (25 - 35 °C) it is ideally suited to being used with eco-friendly fully condensing boilers or alternative energy sources like a heat pump, solar, geothermal and heat recovery systems.

Besides the thermal advantages there is the added benefit of reduced air movement. The result is reduced dust movement with constant humidity.

In conclusion wall heating, resp. ceiling heating, saves 25-30% of energy costs and contributes to a healthy environment. Of course the aquatherm black system for wall and ceiling can be combined with each other.

### Comfort

Moderate temperatures (20 - 35 °C) with large heating surfaces generates steady radiation for the user.

Direct heat radiation on the human body delivers a comfortable warm feeling. The room air temperature can be reduced compared to conventional heating technologies (radiators/convectors) and still provides thermal comfort for the occupant.

## SYSTEM TECHNOLOGY AQUATHERM BLACK SYSTEM

### Visual performance heating, diagonal connection

The photos of the high-resolution camera shows its performance clearly: The aquatherm black system for wall heating delivers an even heat distribution into a room, and provides a comfortable room climate.

#### Example: Metal ceiling panel

Legend:

Room temperature: 20 °C

Linear heating temperature: 32 °C

Radiation surface temperature: see screen sequence

Original metal ceiling panel



Start of heating

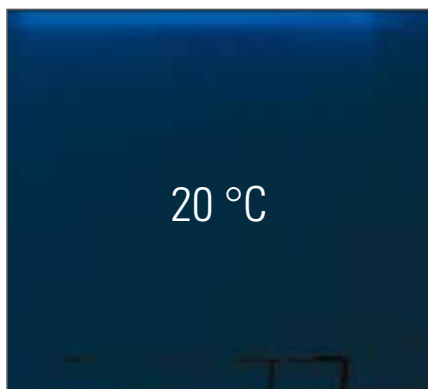

after 1 minute

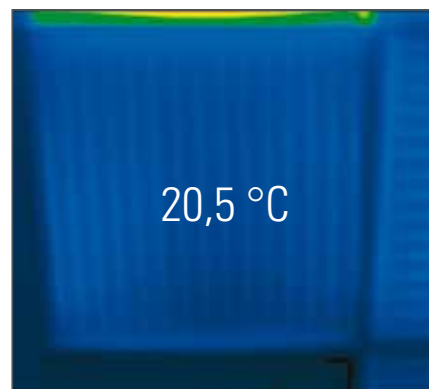

after 1,5 minutes

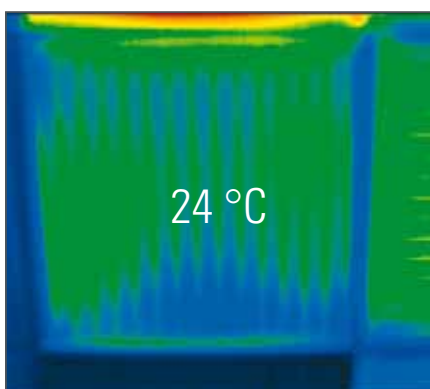

after 2 minutes

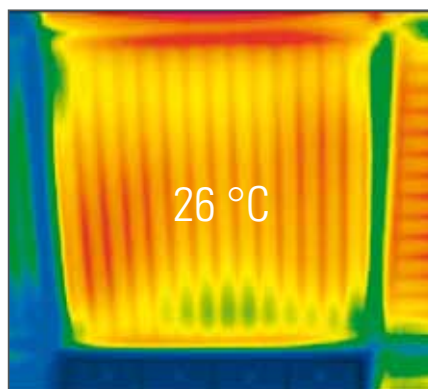

after 2,5 minutes

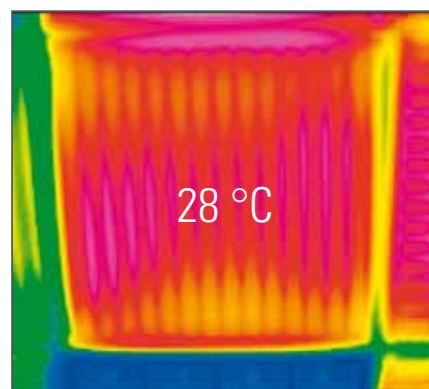

after 3 minutes

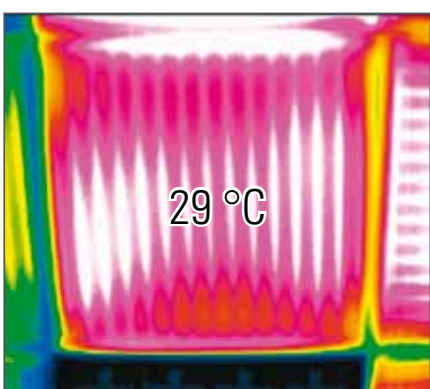

after 3,5 minutes

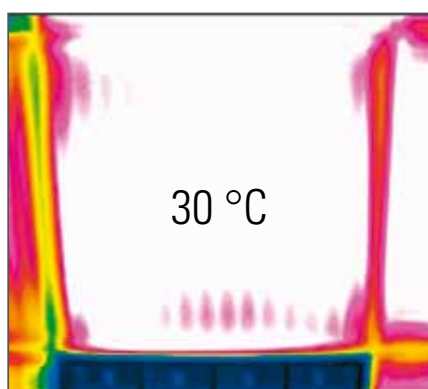

after 4 minutes



## SYSTEM TECHNOLOGY AQUATHERM BLACK SYSTEM

### Visual performance cooling, diagonal connection

The photos of the high-resolution thermal camera show: The aquatherm black system for cooling ceilings produces a constant cooling performance in a room and therefore provides not only a comfortable but also healthy room climate.

#### Example: Metal ceiling panel

Legend:

Room temperature: 24 °C

Linear cooling temperature: 16 °C

Radiation surface temperature: see screen sequence

Original metal ceiling panel



Start of cooling

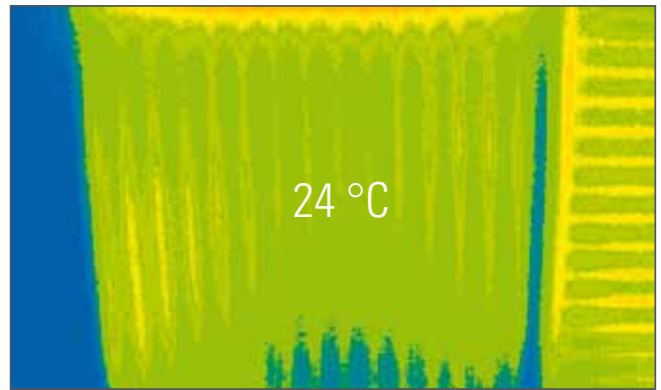

after 1 minute

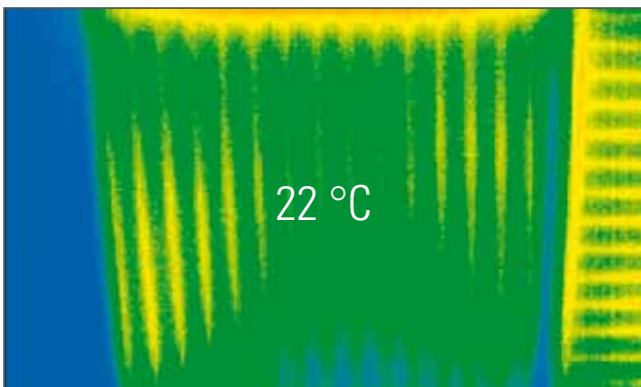

after 2 minutes

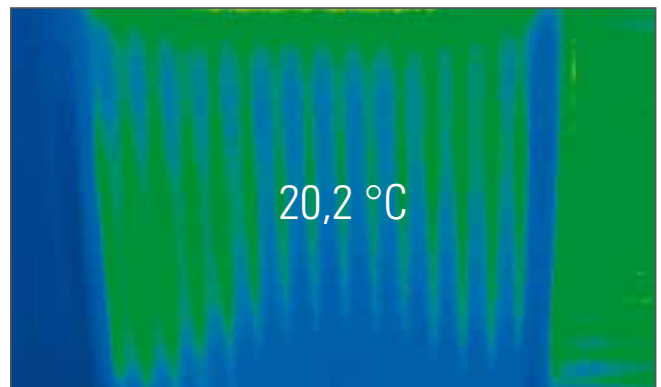

after 4 minutes

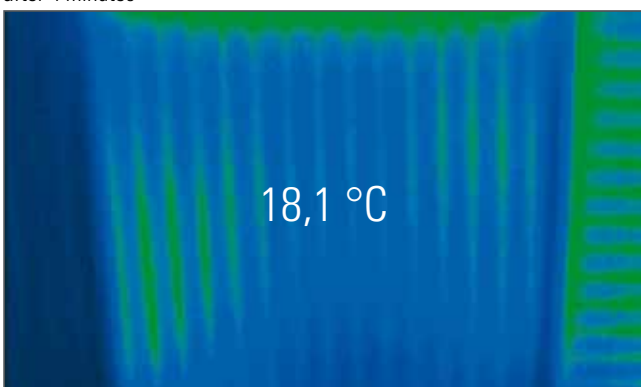

after 6 minutes

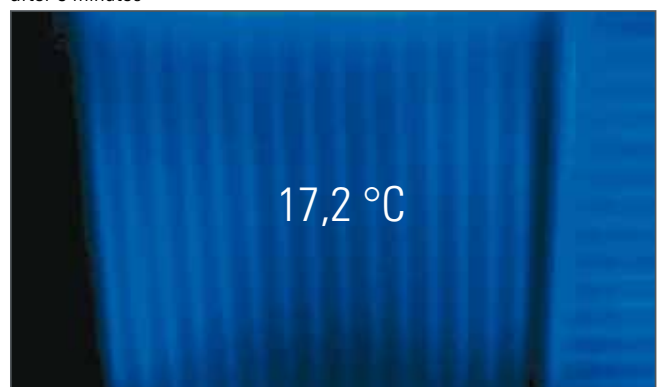

**Visual performance, one-sided connection**

The photos of the high-resolution thermal camera reveal it: The aquatherm black system grid with flow break shows a perfect flow and grants an optimum heat distribution at the wall or ceiling in a little while.

Legend:

Room temperature: 20 °C

Linear heating temperature: 35 °C

Radiation surface temperature: see screen sequence

Start of heating



after 1 minute

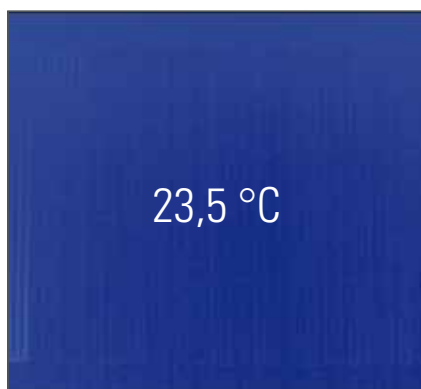

after 2 minutes

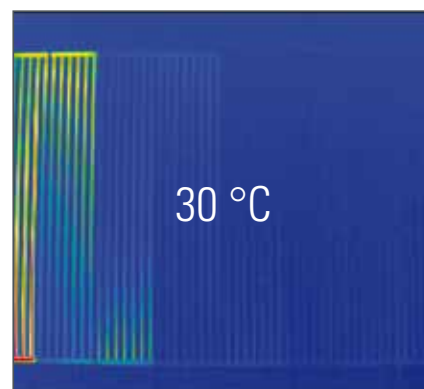

after 3 minutes

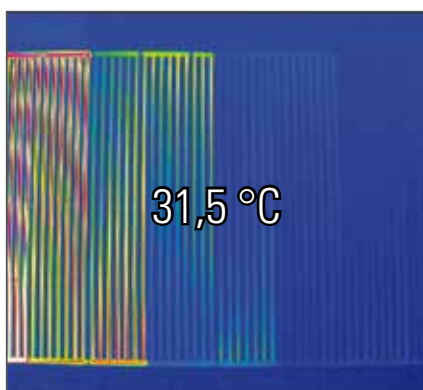

after 4 minutes

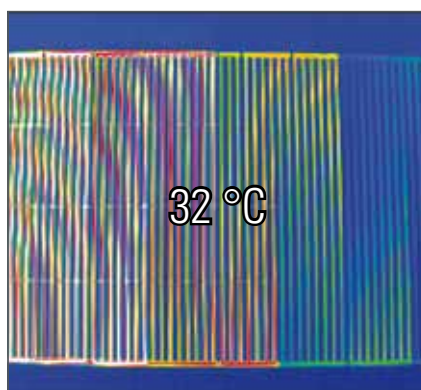

after 5 minutes

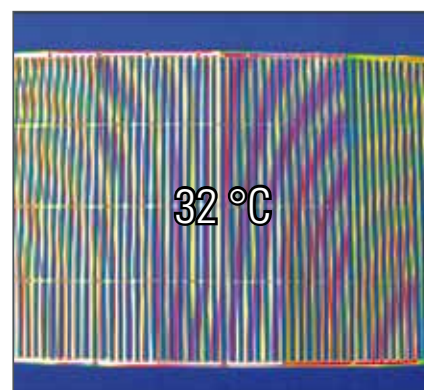

### **Surface temperatures**

The surface temperatures are dependent on the heat efficiency of the wall heating. This also depends on the heat loss of the room/building and on the surface, which is available for the installation of the wall heating.

In addition, the pipe spacing, the surface finishes and the design of the wall heating provide variable differences to the surface temperature.

That means, the temperature above the heating pipes is higher than in the intervals. Even surface temperatures are obtained by the close pipe spacing (40 mm/25 m pipe per m<sup>2</sup>) of the aquatherm black system.

The average surface temperature of wall heating should be regulated for physiological reasons. In rooms with low dwelling time (e.g. baths, swimming pools, therapeutic areas) the surface temperature is limited to 35 °C and in rooms with long dwelling time (e.g. living rooms, day rooms, offices) it is limited to 30 °C.

### **Surface considerations**

In the planning stage of wall heating design the future use should be taken into consideration. When arranging the grids personal and spatial needs can be considered. The placement of large furniture must be considered, while smaller furniture (e.g. desk, seat set and pictures) can be disregarded. Thus the outside wall often remains as a possible option.

### **Conduits and cables**

Conduits and cables which are placed on the weight-bearing subsurface, must be well fixed. They can be surface mounted or concealed behind the aquatherm black system.

### **Expansion joint**

To accommodate length expansion of the wall and ceiling construction, suitable expansion to the near-by construction parts must be allowed for.

This can be achieved by a flexible joint.

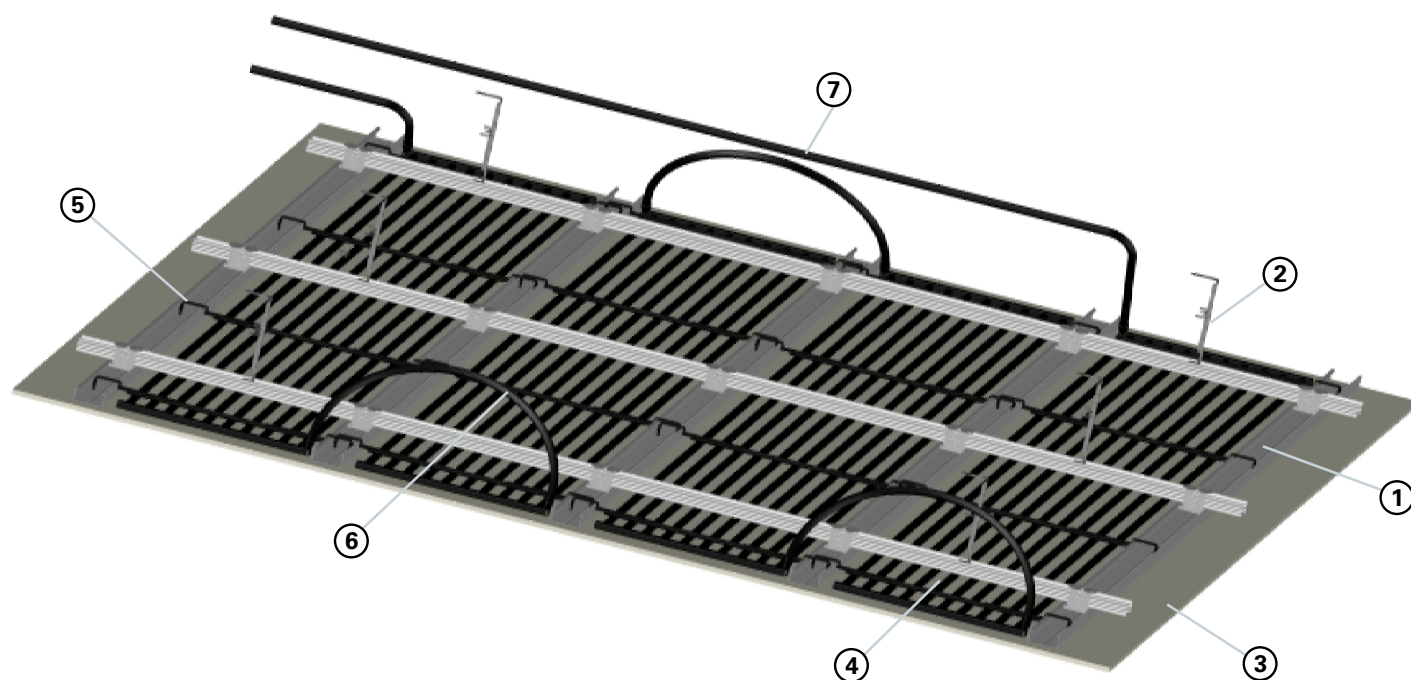

Connection systems

**PLASTERBOARD CEILING WITH METAL SUBSTRUCTURE****Recommended type of grid: connection type 59**

- |                       |  |                                   |
|-----------------------|--|-----------------------------------|
| ① Support profile     | ④ aquatherm black system grid (connection type 59) | ⑦ PP grid connecting pipe (81026) |
| ② Hanger              | ⑤ Fixing rail for dry construction (81297)         |                                   |
| ③ Gypsum plasterboard | ⑥ Corrugated connecting pipe (81039)               |                                   |

**Description**

The aquatherm black system grids for heating and cooling are clamped between the furring strips of the substructure of a conventional gypsum board. Then the ceiling is covered with gypsum plaster boards, which may have different thermal conductivities.

**Installation****1. Substructure**

The basic and furring strips acc. to DIN 18168-1 are fixed and arranged, subject to manufacturer's instructions, with hangers (e.g. Noniushanger) at the slab.

**2. Installation of the grids**

The middle suspending height should be 15 cm for a smooth installation. The axis distance, between 300 and 500 mm, of the support construction depends on the applied gypsum board. The connection pipe of the heating and cooling circuits from the manifold or the main supply is fixed in the cavity at the ceiling and is directed in the room. The grids, object-related and made to measure, are hung between the furring strips. Therefore the fixing rail for dry construction is pushed on both sides of the fixing rail at the grid and fixed with the integrated cable tie. Now the grid can be hung between the furring strips. The fixing rail for dry construction is clicked in the CD-profile. The required number is listed in the table on page 27.

**3. Connection of the grids**

The grids for the installation in a plasterboard ceiling are supplied with two-way welding nipples. After hanging the grids in the substructure they are interconnected to heating respectively cooling areas according to the layout drawing. Therefore the aquatherm black system corrugated pipe from the coil

is used, which is separable each 25 cm and can be cut to the required length. The corrugated pipe is welded directly in the welding socket at the grid by heating element socket welding.

The maximum area per heating circuit is 15 m<sup>2</sup>.

The maximum area per cooling circuit is described on page 70.

The heating and cooling circuits are connected to the manifold or the main supply with aquatherm black system PP grid pipe 16 x 2 mm or alternative connection systems (e.g. aquatherm grey pipe).

**4. Installation at the gypsum plasterboard**

The grid hangs some millimeter below the supporting rail. If now the gypsum boards are screwed at the support construction, they will press the lightly sagging grids upwards. As the grid cannot be pushed upwards due to the fixing rail for dry construction, there is a contact between the gypsum board and the grid. Note that the grids are filled with water and are pressurized during the planking.

Connection systems

**PLASTERBOARD CEILING WITH WOODEN SUBSTRUCTURE IN VAULTED ROOFS, ONE-SIDE CONNECTION**

Recommended type of grid: connection type 64

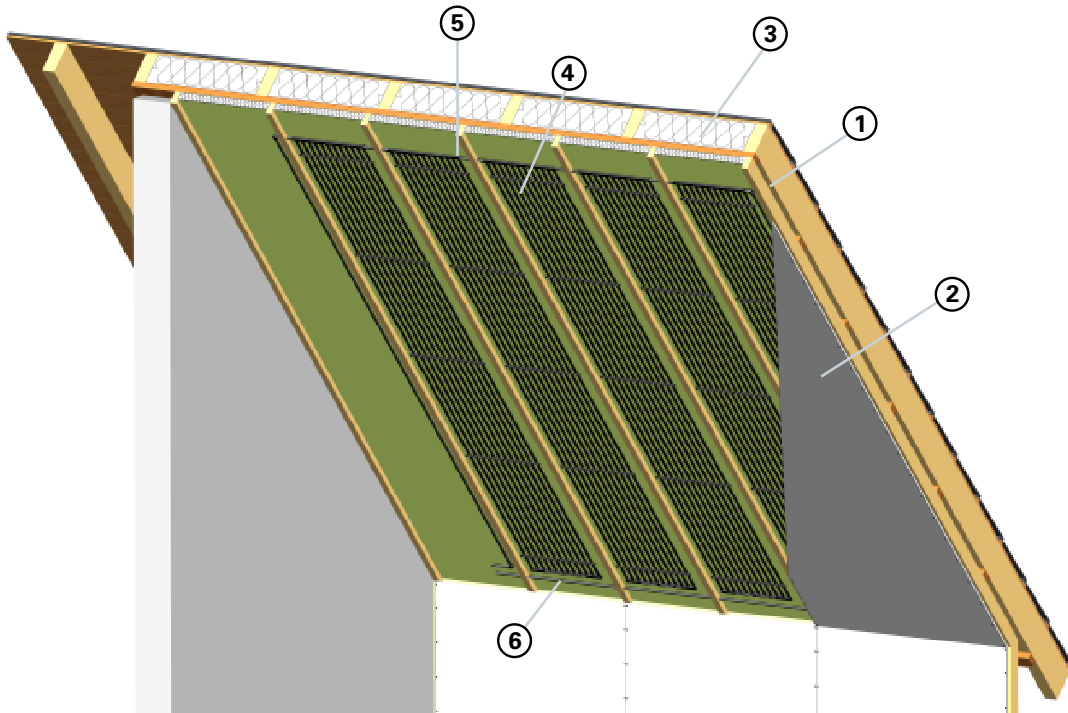

- ① Joist
- ② Gypsum plasterboard
- ③ Insulation
- ④ aquatherm black system grid (connection type 64)
- ⑤ Corrugated connecting pipe or PP-grid connecting pipe (81039 or 81006)
- ⑥ PP grid connecting pipe (81026)

**Description**

The aquatherm black system grids for heating and cooling are clamped between the wooden furring strips of the substructure of a conventional gypsum board. Then the ceiling is covered with gypsum plaster boards, which may have different thermal conductivities.

**Installation**

**1. Substructure**

The joist and wooden furring strips are fixed and arranged, subject to manufacturer’s instructions.

**2. Installation of the grids**

The axis distance, between 300 and 500 mm, of the support construction depends on the applied gypsum board. The connection pipe of the heating and cooling circuits from the manifold or the main supply is fixed in the cavity at the ceiling and is directed in the room. The grids, object-related and made to measure, are hung between the furring strips according to the layout drawing. Therefore the fixing rail for dry construction is pushed on both sides of the fixing rail at the grid and fixed with the integrated cable tie. Now the fixing rail for dry construction can be screwed sidewise in the support pole. If this is not possible, the grids can be fixed at the joist with screws, which are screwed through the fixing rail at the grid.

**3. Connection of the grids**

For the horizontal arrangement of aquatherm black system grids the flow can be connected optionally left or right. The grids of this system have a one-sided socket connection with a forced flow. The grids can be connected one-sided and a constant flow is assured.

After hanging the grids in the substructure they are interconnected to heating respectively cooling areas according to the layout drawing. Therefore the aquatherm black system corrugated pipe from the coil is used, which is separable each 25 cm and can be cut to the required length. The corrugated pipe is welded with an elbow directly at the grid by heating element socket welding, respectively it is directed behind or through the wooden furring strips and connected with the next grid.

The maximum area per heating circuit is 15 m².

The maximum area per cooling circuit – see page 70.

The heating and cooling circuits are connected to the manifold or the main supply with aquatherm black system PP grid pipe 16x2 mm or alternative connection systems (e.g. aquatherm grey pipe).

**4. Installation at the gypsum plasterboard**

Note even here that the grid hangs some millimeter lower than the support pole. Now the grids are cased together and connected to the connection pipe. If now the gypsum boards are screwed at the support construction subject to manufacturer’s instructions, they will press the lightly sagging grids upwards. As the grid cannot be pushed upwards due to the fixing rail for dry construction respectively due to the insulation in the pitched roof, there is a contact between the gypsum board and the grid. Note that the grids are filled with water and are pressurized during the planking.

Connection systems

## PLASTERBOARD CEILING WITH WOODEN SUBSTRUCTURE IN ROOFS, WITH SERIES CONNECTION

Recommended type of grid: connection type 50

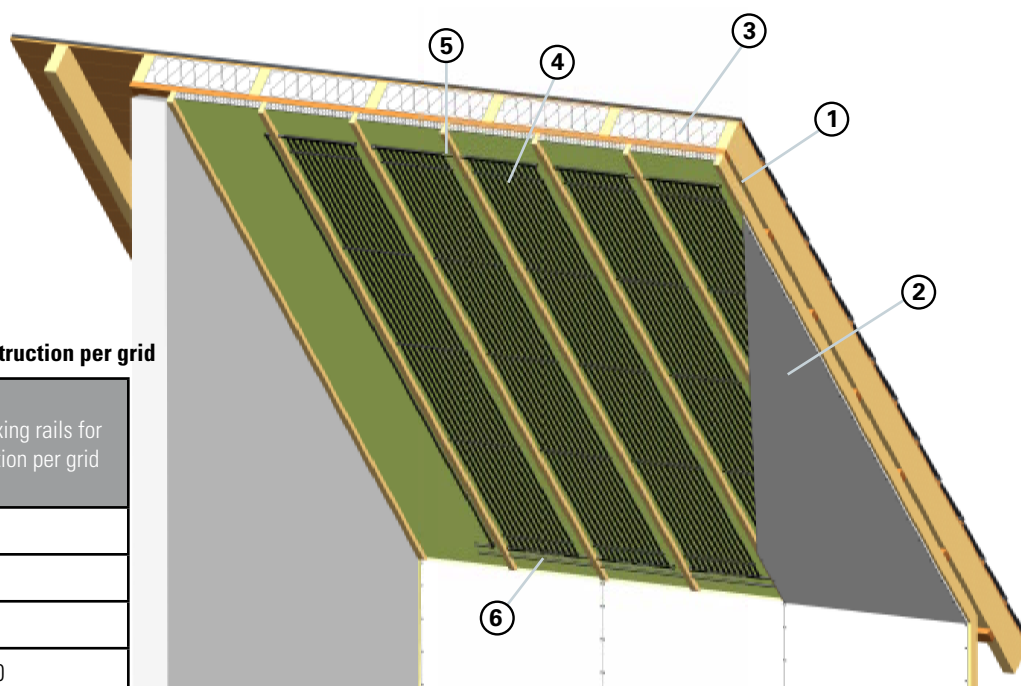

**Number of fixing rails for dry construction per grid**

Lengths of grids	Number of fixing rails for dry construction per grid
up to 140 cm	4
up to 250 cm	6
up to 350 cm	8
up to 450 cm	10
up to 500 cm	12

- ① Joist
- ② Gypsum plaster board
- ③ Insulation
- ④ aquatherm black system grid (connection type 50)
- ⑤ Corrugated connecting pipe (81039 or 81006)
- ⑥ PP grid connecting pipe (81026)

### Description

The aquatherm black system grids for heating and cooling are clamped between the wooden furring strips of the substructure of the vaulted roof of a conventional gypsum board. Then the ceiling is covered with gypsum plaster boards, which may have different thermal conductivities.

### Installation

#### 1. Substructure

The joist and wooden furring strips are fixed and arranged, subject to manufacturer's instructions.

#### 2. Installation of the grids

The axis distance, between 300 and 500 mm, of the support construction depends on the applied gypsum board. The connection pipe of the heating and cooling circuits from the manifold or the main supply is fixed in the cavity at the ceiling and is directed in the room. The grids, object-related and made to measure, are hung between the furring strips according to the layout drawing. Therefore the fixing rail for dry construction is pushed on both sides of the fixing rail at the grid and fixed with the integrated cable tie. Now the fixing rail for dry construction can be screwed sidewise in the support pole. Note that the grid hangs some millimeter lower than the support hole. If this is not possible, the grids can be fixed at the joist with screws, which are screwed through the fixing rail at the grid. Note even here that the grid hangs some millimeter lower than the support pole. Now the grids are cased together and connected to the connection pipe.

#### 3. Connection of the grids

For the horizontal arrangement of aquatherm black system grids the flow can be connected optionally left or right. The grids are connected in series to assure a constant flow. Thus the return of the grids is opposite to the flow.

After hanging the grids in the substructure they are interconnected to heating respectively cooling areas according to the layout drawing. Therefore the aquatherm black system corrugated pipe from the coil is used, which is separable each 25 cm and can be cut to the required length. The corrugated pipe is welded with an elbow directly at the grid by heating element socket welding, respectively it is directed behind or through the wooden furring strips and connected with the next grid. Alternatively the aquatherm black system PP grid pipe 16 x 2 can be applied.

The maximum area per heating circuit is 15 m<sup>2</sup>.

The maximum area per cooling circuit is described on page 70.

The heating and cooling circuits are connected to the manifold or the main supply with aquatherm black system PP grid pipe 16 x 2 mm or alternative connection systems (e.g. aquatherm grey pipe).

#### 4. Installation at the gypsum plasterboard

If now the gypsum boards are screwed at the support construction subject to manufacturer's instructions, they will press the lightly sagging grids upwards. As the grid cannot be pushed upwards due to the fixing rail for dry construction respectively due to the insulation in the vaulted roof, there is a contact between the gypsum board and the grid. Note that the grids are filled with water and are pressurized during the planking.

## PERFORMANCE VALUE OF GYPSUM PLASTER BOARD

Standard **heating** performance acc. to DIN EN 14037-2

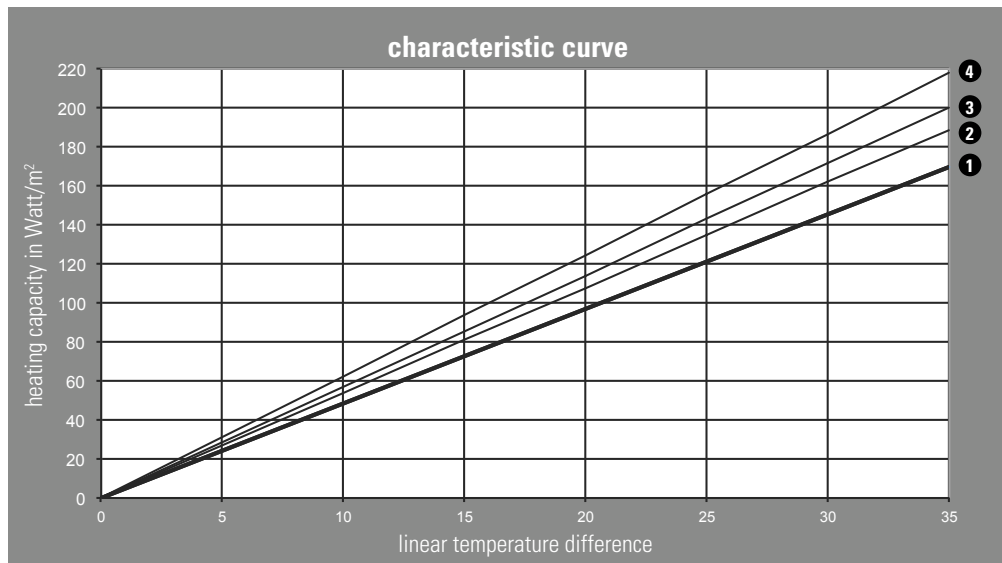

characteristic curve

- ① Gypsum plaster board 12,5mm
- ② Knauf Thermoboard
- ③ Knauf Thermoboard Plus
- ④ Rigips climafit

Calculation example: Flow temperature 40 °C / Return temperature 35 °C

linear temperature difference K	13,5	15,5	17,5	19,5	22,5	25,5
Room temperature °C	24	22	20	18	15	12
① Gypsum plaster board 12,5 mm	65	75	86	96	111	127
② Knauf Thermoboard	72	84	95	107	124	142
③ Knauf Thermoboard Plus	77	88	100	112	129	146
④ Rigips climafit	84	96	109	122	142	161

Standard **cooling** performance acc. to DIN EN 14240: 2004-04

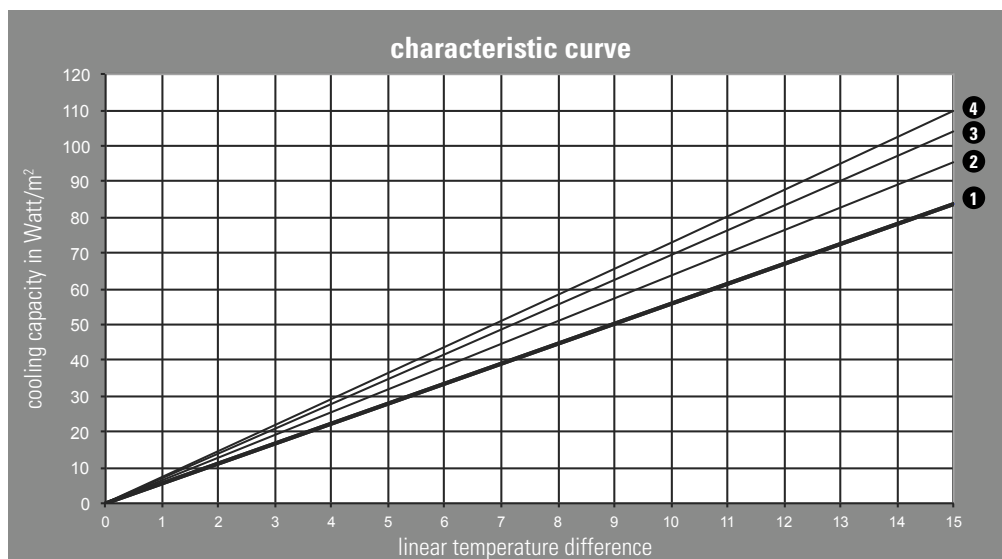

characteristic curve

- ① Gypsum plaster board 12,5 mm
- ② Knauf Thermoboard
- ③ Knauf Thermoboard Plus
- ④ Rigips climafit

Calculation example: Flow temperature 15 °C / Return temperature 17 °C

linear temperature difference K	6	8	10
Room temperature °C	22	24	26
① Gypsum plaster board 12,5 mm	32	44	56
② Knauf Thermoboard	36	50	63
③ Knauf Thermoboard Plus	41	55	70
④ Rigips climafit	43	58	73

Connection systems

**METAL CEILING PANEL AS CLIP-IN SYSTEM****Recommended type of grid: connection type 62**

- ① Clip-in profile
- ② Metal panel with aquatherm black system grid (connection type 62)
- ③ Corrugated connecting pipe with 90° plug adapter (81032)
- ④ PP-grid connecting pipe (81026)

**Description**

The aquatherm black system grids for heating and cooling are laid on the metal ceiling panels, respectively are glued on. Thus the square pipes lay directly on the metal plate respectively on the acoustical mat. That guarantees a good power transmission, and a quick cooling respectively heating of less than 10 minutes is possible.

**Installation****1. Substructure**

The basic- and terminal strips are fixed and aligned according to manufacturer's instructions with hangers at the slab.

**2. Installation of the grids**

For a smoothly installation the middle suspending height should be 15 cm. The size of the panels is normally 625 x 625 mm resp. 625 x 1250 mm. The connection pipe of the heating and cooling circuits from the manifold or the main supply is fixed in the cavity at the ceiling and is directed in the room. The grids, object-related and made to measure, are laid on the panels, resp. glued on with special glue according to the layout plan. Depending on the requirements a rock wool insulation (min. 30 mm), welded in a PE-film, can be laid on the grids.

**3. Connection of the grids**

The grids for the installation in a clip-in system ceiling are supplied with one-side plug socket 90° with flow break. Thus the constant flow is guaranteed and the grids can be connected to one side. After hanging the grids in the terminal strips of the metal panels they are interconnected to heating respectively cooling areas according to the layout drawing. Therefore the pre-fabricated aquatherm black system corrugated pipes with 90° plug adapters are used. The corrugated connecting pipe must be long enough to open the ceiling

in the pretended opening direction without problems. The transition to the connection supply is made with a socket by heating element socket welding. But also pre-fabricated connection supplies with a calibrated plug socket can be applied. Also the connection with plug adapters is possible.

The maximum area per heating circuit is 15 m<sup>2</sup>.

The maximum area per cooling circuit is described on page 70.

The heating and cooling circuits are connected to the manifold or the main supply with aquatherm black system PP grid pipe 16x2 mm or alternative connection systems (e.g. aquatherm grey pipe).

**4. Installation at the clip-in panel ceiling**

The so pre-fabricated panels are hung vertically in the terminal strips according to manufacturer's instructions. Now, the grids are cased together and connected to the connection pipe. The grids are filled with water and are pressurized. Then the complete ceiling is closed by the drywall builder.

Connection systems

## METAL CEILING PANEL AS CLIP-IN SYSTEM

Recommended type of grid: connection type 51



- ① Clip-in profile
- ② Metal panel with aquatherm black system grid (connection type 51)
- ③ Corrugated connecting pipe with plug adapter (81040)
- ④ PP-grid connecting pipe (81026)

### Description

The aquatherm black system grids for heating and cooling are laid on the metal ceiling panels, respectively are glued on. Thus the square pipes lay directly on the metal plate respectively on the acoustic mat. That guarantees an efficient power transmission, and a quick cooling respectively heating of less than 10 minutes is possible.

### Installation

#### 1. Substructure

The basic- and furring stripes are fixed and aligned according to manufacturer's instructions with hangers at the slab.

#### 2. Installation of the grids

For a smoothly installation the middle suspending height should be 15 cm. The size of the panels is normally 625 x 625 mm resp. 625x1250 mm. The connection pipe of the heating and cooling circuits from the manifold or the main supply is fixed in the cavity at the ceiling and is directed in the room. The grids, object-related and made to measure, are laid on the panels, resp. glued on with special glue according to the layout plan. Depending on the requirements a rock wool insulation (min. 30 mm), welded in a PE-film, can be laid on the grids.

#### 3. Connection of the grids

The grids for the installation in a clip-in system ceiling are supplied with two-way plug socket 45°. After hanging the grids in the furring stripes of the metal panels they are interconnected to heating respectively cooling areas according to the layout drawing. Therefore the pre-fabricated aquatherm black system corrugated pipes with 45° plug adapters are used. The corrugated

connecting pipe must be long enough to open the ceiling in the pretended opening direction without problems. The transition to the connection supply is made with a socket by heating element socket welding. But also pre-fabricated connection supplies with a calibrated plug socket can be applied. Also the connection with plug adapters is possible.

The maximum area per heating circuit is 15 m<sup>2</sup>.

The maximum area per cooling circuit is described on page 70.

The heating and cooling circuits are connected to the manifold or the main supply with aquatherm black system PP grid pipe 16 x 2 mm or alternative connection systems (e.g. aquatherm grey pipe).

#### 4. Installation at the clip-in panel ceiling

The so pre-fabricated panels are hung vertically in the furring stripes according to manufacturer's instructions. Now, the grids are cased together and connected to the connection pipe. The grids are filled with water and are pressurized. Then the complete ceiling is closed by the drywall builder.

Connection systems

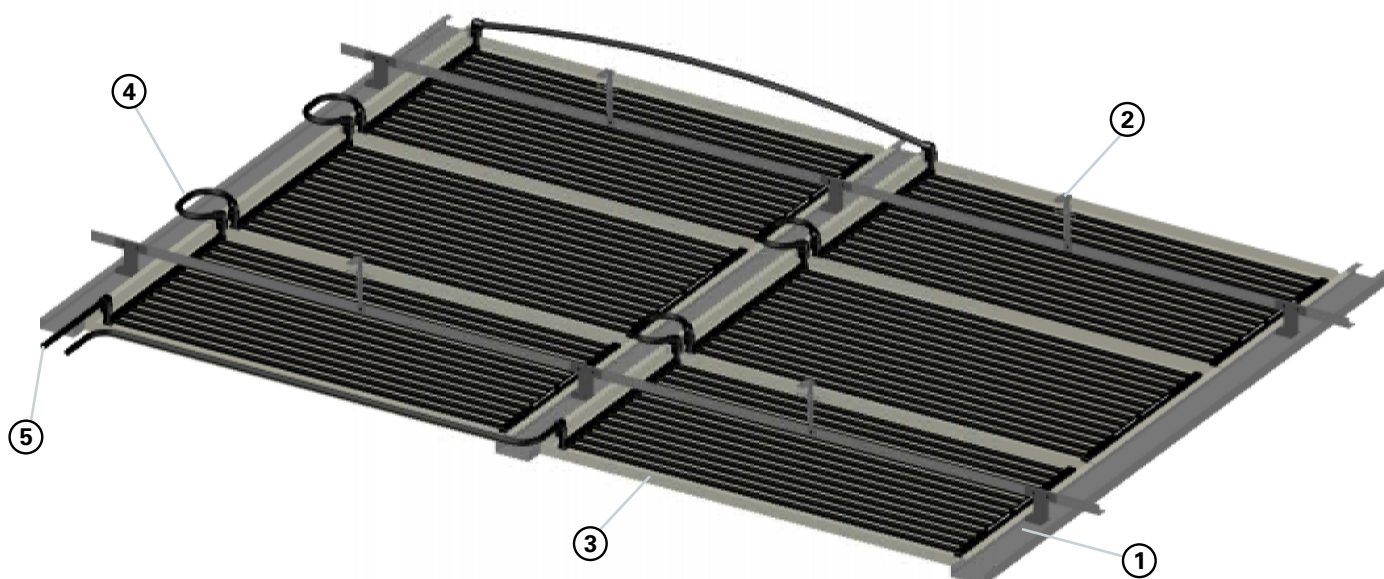
**METAL CEILING PANEL AS STRIP GRID SYSTEM****Recommended type of grid: connection type 62**

- ① Strip grid system
- ② Hanger
- ③ Metal panel with aquatherm black system grid (connection type 62)
- ④ Corrugated connecting pipe with 90°-plug adapter (81032)
- ⑤ PP-grid connecting pipe (81026)

**Description**

The aquatherm black system grids for heating and cooling are laid on the metal ceiling panels, respectively are glued on. Thus the square pipes lay directly on the metal plate respectively on the acoustic mat. That guarantees an efficient power transmission, and a quick cooling respectively heating of less than 10 minutes is possible.

**Installation****1. Substructure**

The strip grid system profiles are fixed and aligned according to manufacturer's instructions with hangers at the slab.

**2. Installation of the grids**

For a smoothly installation the middle suspending height should be 15 cm. In this system the size of the panels can vary very much. The connection pipe of the heating and cooling circuits from the manifold or the main supply is fixed in the cavity at the ceiling and is directed in the room. The grids, object-related and made to measure, are laid on the panels, resp. glued on with special glue according to the layout plan. Depending on the requirements a rock wool insulation (min. 30 mm), welded in a PE-film, can be laid on the grids.

**3. Connection of the grids**

The grids for the installation in a clip-in system ceiling are supplied with one side plug socket 90° with flow break. Thus the constant flow is guaranteed and the grids can be connected to one side. After hanging the grids in the furring stripes of the metal panels they are interconnected to heating respectively cooling areas according to the layout drawing. Therefore the pre-fabricated aquatherm black system corrugated pipes with 90° plug adapters are used. The corrugated connecting pipe must be long enough to open the ceiling in

the pretended opening direction without problems. The transition to the connection supply is made with a socket by heating element socket welding. But also pre-fabricated connection supplies with a calibrated plug socket can be applied. Also the connection with plug adapters is possible.

The maximum area per heating circuit is 15 m<sup>2</sup>.

The maximum area per cooling circuit is described on page 70.

The heating and cooling circuits are connected to the manifold or the main supply with aquatherm black system PP grid pipe 16 x 2 mm or alternative connection systems (e.g. aquatherm grey pipe).

**4. Installation at the strip grid system**

The so pre-fabricated panels are hung horizontally or vertically in the strip grid system profiles according to manufacturer's instructions. Now, the grids are cased together and connected to the connection pipe. The grids are filled with water and pressurized. Then the complete ceiling is closed by the drywall builder.

## PERFORMANCE VALUE OF METAL PANEL CEILING

Standard **heating** performance acc. to DIN EN 14037-2

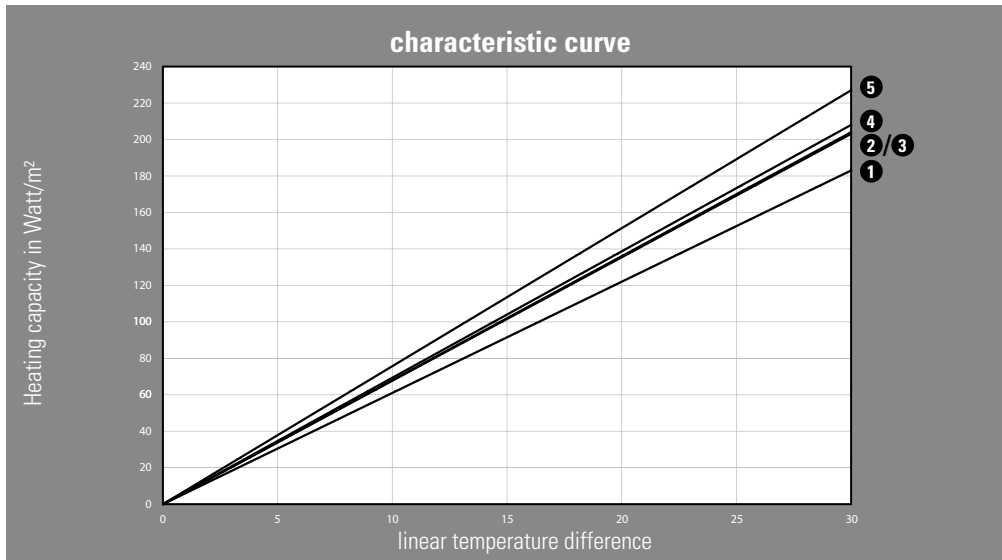

characteristic curve

- ① Clip-in panel
- ② Strip grid system with acoustical mat
- ③ Strip grid system with micro perforation
- ④ Strip grid system without acoustical mat
- ⑤ Expanded metal

Calculation example: Flow temperature 40 °C / Return temperature 35 °C

linear temperature difference K	13,5	15,5	17,5	19,5	22,5	25,5
Room temperature °C	24	22	20	18	15	12
① Clip-in panel	81	94	106	118	137	155
② Strip grid system with acoustical mat	87	100	114	128	148	169
③ Strip grid system with micro perforation	89	102	116	130	151	172
④ Strip grid system without acoustical mat	91	105	119	133	154	176
⑤ Expanded metal	95	111	127	142	166	191

Standard **cooling** performance acc. to DIN EN 14240: 2004-04

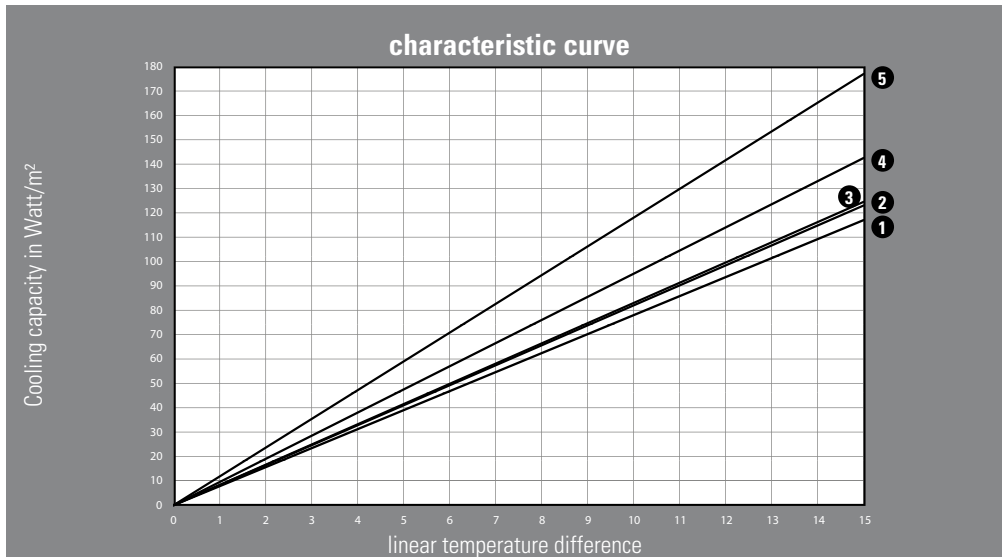

characteristic curve

- ① Clip-in panel
- ② Strip grid system with acoustical mat
- ③ Strip grid system with micro perforation
- ④ Strip grid system without acoustical mat
- ⑤ Expanded metal

Calculation example: Flow temperature 15 °C / Return temperature 17 °C

linear temperature difference K	6	8	10
Room temperature °C	22	24	26
① Clip-in panel	45	62	78
② Strip grid system with acoustical mat	48	65	82
③ Strip grid system with micro perforation	49	66	93
④ Strip grid system without acoustical mat	53	74	95
⑤ Expanded metal	65	91	118

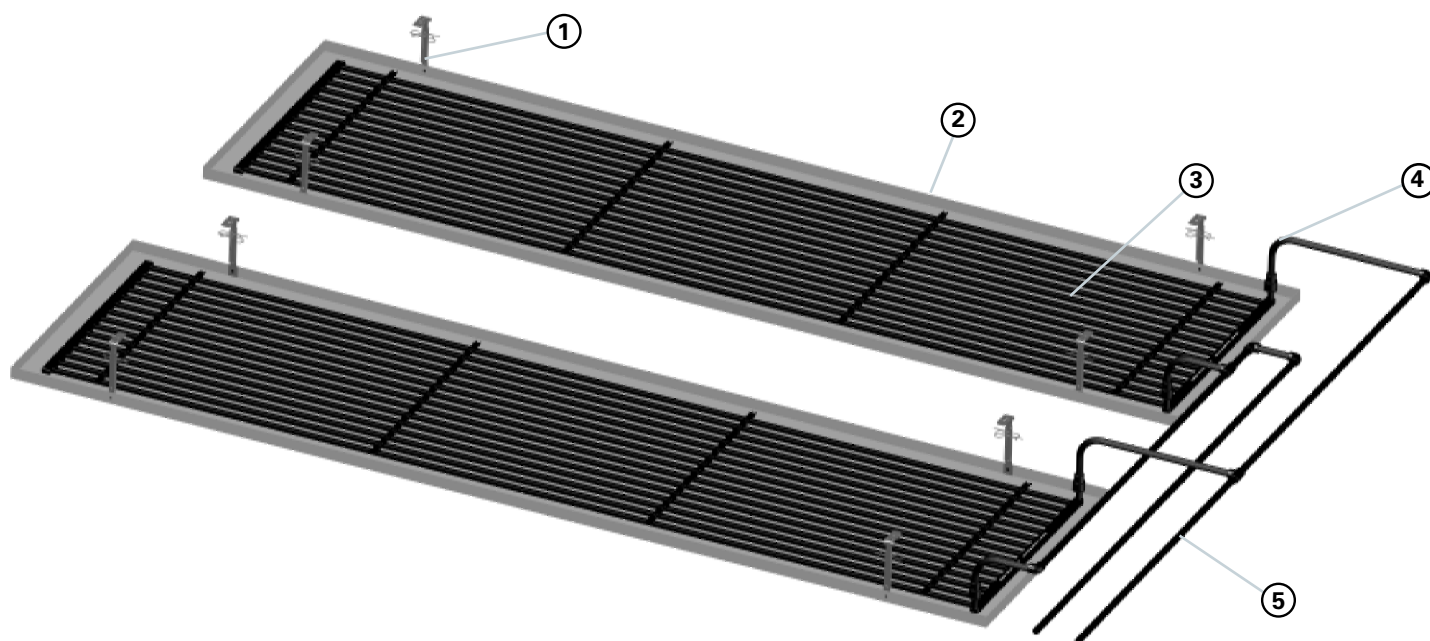

Connection systems

**FREELY FLOATING CEILING****Recommended type of grid: connection type 62**

- |  |                                      |
|--|--------------------------------------|
| ① Hanger   | ④ Corrugated connecting pipe (81031) |
| ② Freeley floating ceiling                         | ⑤ PP connecting pipe (81026)         |
| ③ aquatherm black system-grid (connection type 62) |                                      |

**Description**

The aquatherm black system grids for heating and cooling are laid on the metal ceiling panels, respectively are glued on. Thus the square pipes lay directly on the metal plate respectively on the acoustic mat. That guarantees an efficient power transmission, and a quick cooling respectively heating of less than 10 minutes is possible. A great increase in efficiency compared to metal panel ceilings results from the convective share of the system.

**Installation****1. Substructure**

The connection pipe of the heating and cooling circuits from the manifold or the main supply is fixed at the ceiling and directed into the room. The grids, object-related and made to measure, are laid on the panels, resp. glued on with special glue according to the layout plan. Depending on the requirements a rock wool insulation (min. 30 mm), welded in a PE-film, can be laid on the grids. Consider that the convective share of the ceiling gets lost and the cooling efficiency decreases by fitting of the insulation. Insulation is only recommended for pure heating floating panels.

**2. Installation of the grids**

The grids for the installation in a clip-in system ceiling are supplied with one side plug socket 90° with flow break. Thus the constant flow is guaranteed and the grids can be connected to one side. After hanging the grids in the clamp rails of the metal panels they are interconnected to heating respectively cooling areas according to the layout drawing. Therefore the pre-fabricated aquatherm black system corrugated pipes with 90° plug adapters are used. The corrugated connecting pipe must be long enough to open the ceiling in the pretended opening direction without problems. The transition to the

connection supply is made with a socket by heating element socket welding. But also pre-fabricated connection supplies with a calibrated plug socket can be applied. Also the connection with plug adapters is possible.

The maximum area per heating circuit is 15 m<sup>2</sup>.

The maximum area per cooling circuit is described on page 70.

The heating and cooling circuits are connected to the manifold or the main supply with aquatherm black system PP grid pipe 16x2 mm or alternative connection systems (e.g. aquatherm grey pipe).

**3. Installation of the freely floating ceiling**

The pre-fabricated panels are fixed and aligned with hangers at the slab, according to manufacturer's instructions. A suspending height of at least 10 cm is required to ensure convection. Now, the grids are cased together and connected to the connection pipe. The grids are filled with water and are pressurized.

### PERFORMANCE VALUE FREELY FLOATING CEILING

Standard **heating** performance acc. to DIN EN 14037-2

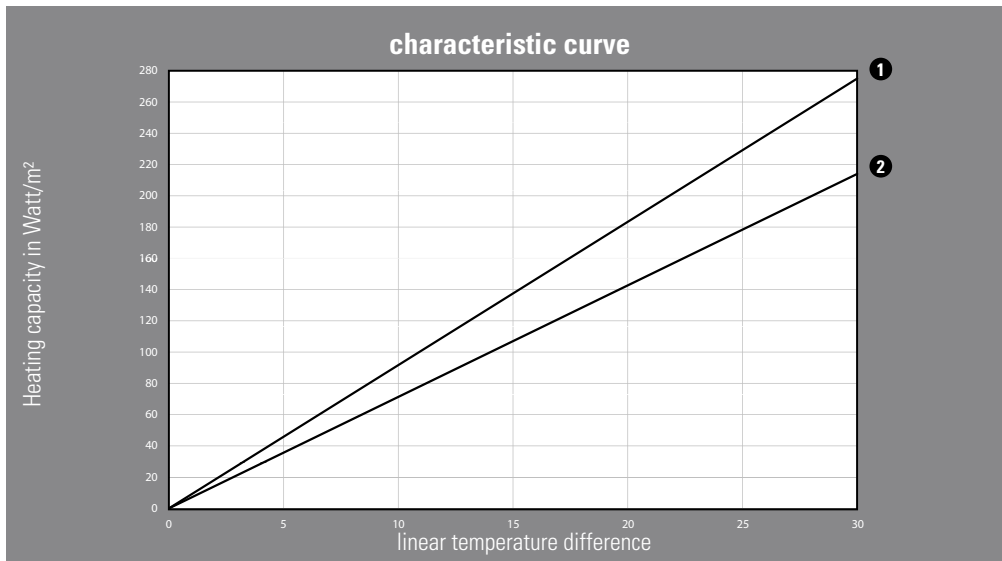

characteristic curve

- 1 Free convection
- 2 Freely floating ceiling width 0,5 / 1,0 / 3,0 m

Calculation example: Flow temperature 40 °C / Return temperature 35 °C

linear temperature difference K		13,5	15,5	17,5	19,5	22,5	25,5
Room temperature °C		24	22	20	18	15	12
1	Free convection	114	133	152	171	200	230
2	Freely floating ceiling width 0,5 / 1,0 / 3,0 m	96	110	124	139	160	182

Standard **cooling** performance acc. to DIN EN 14240: 2004-04

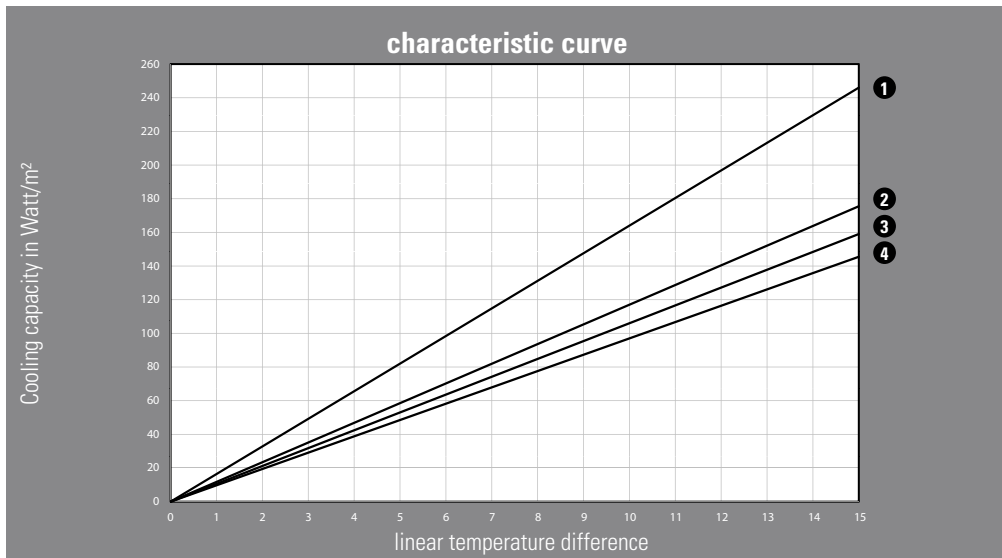

characteristic curve

- 1 Free convection
- 2 Freely floating ceiling width 0,5 m
- 3 Freely floating ceiling width 1,0 m
- 4 Freely floating ceiling width 3,0 m

Calculation example: Flow temperature 15 °C / Return temperature 17 °C

linear temperature difference K		6	8	10
Room temperature °C		22	24	26
1	Free convection	93	128	164
2	Freely floating ceiling width 0,5 m	68	92	117
3	Freely floating ceiling width 1,0 m	61	84	106
4	Freely floating ceiling width 3,0 m	56	76	97

Connection systems

## PLASTER CEILING, ONE-SIDE CONNECTION

Recommended type of grid: connection type 64/65

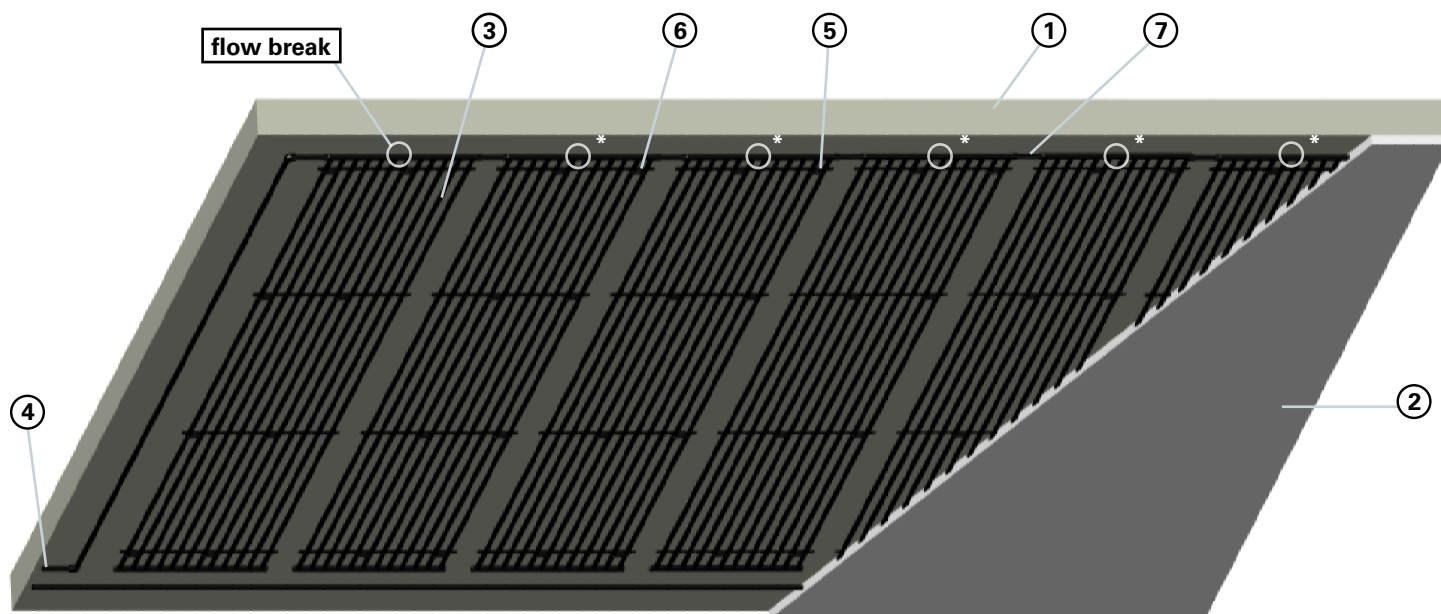

- |   |                                       |                                   |
|---|---------------------------------------|-----------------------------------|
| ① Unfinished surface  | ④ PP-grid connecting pipe (81006)     | ⑥ Fixing rail (81506)             |
| ② Plaster   | ⑤ Fixing clamp with wall plug (81298) | ⑦ PP grid connecting pipe (81006) |
| ③ aquatherm black system grid (connection type 64/65) with flow break |                                       |                                   |

### Description

The aquatherm black system grids for heating and cooling are integrated in a plaster layer directly below the slab. First the grids, object-related and made to measure, and the connection supply are fixed below the ceiling. Then the ceiling is plastered according to general plastering regulations. All commercial plasters made of gypsum, chalk, concrete and clay are suitable.

### Installation

#### 1. Substructure

For carrying the plaster the unfinished surface must be dry and even. Normally, plaster can be used on all plaster unfinished surfaces. With regard to the adhesion there are differences between the unfinished surfaces. The choice of plaster, the working process and the pretreatment of the unfinished surface have to be adjusted to the conditions. The check of the unfinished surface by the contractor (fettler) is compulsory acc. to VOB part C, DIN 18350 resp. acc. to VOB, part B, DIN 1961. The tolerances of the height and the inclination of the ground must correspond to DIN 18202. The insulation of modern houses is already made at the outside wall.

Plasterworks should be made only by specialists with appropriate certificates. The check of the ground conditions for plasterworks is made by the specialist companies. Depending on the processing (single layer or two-ply) only the thickness of the layer changes for the installation of heating grids.

The ground check of the specialist company is made by

- optical check
- smear test (hand check)
- scraping test (putty)
- moistening test (check, if there are rests of release agent)
- CM-device (measuring of moisture)
- temperature measuring (deep temperatures)

After the ground check the material for pretreatment is selected.

Suitable methods are:

- primer coat
- anti-porosity treatment
- primer
- metallic plaster base (for critical grounds)

Basically the instructions of the plaster manufacturer must be observed.

#### 2. Installation of the grids

The grids are fixed at the slab with aquatherm black system fixing clamps with wall plugs according to the assembly drawings.

The fixing clamp is plugged through the fixing rail, which is mounted spaced in the grids, in the slab. Consider that the fixing clamp with wall plug in connection with the fixing rail can serve as plaster base at the ceiling depending on the plaster base, type and manufacturer. Additional plaster bases in the field of the grids are not required. But in the plaster areas without grids suitable measures have to be carried out. Processing guidelines of the plaster manufacturers must be observed binding and mandatory. At least four pieces of fixing clamps with wall plug are required per m<sup>2</sup> of installed surface. But as the grids have to be fixed even at the ceiling and may not be sagging, more aquatherm black system fixing clamps with wall plug have to be installed for the plaster works. The required number is listed in the table on page 38. The connection of the grids to each other respectively of the grids to the manifold is made with the aquatherm black system PP grid pipe 16 x 2 mm. Even this may be plastered if it has been fixed at the ceiling (e.g. with aquatherm black system plastic fixing clips).

### 3. Connection of the grids

If the aquatherm black system grids are arranged horizontally, the flow can be connected optionally left or right.

In this system grids with one-sided socket connection with forced flow are used. That grants a constant flow and the grids can be connected one-sided.

The maximum area per heating circuit is 15 m<sup>2</sup>.

The maximum area per cooling circuit is described on page 70.

The heating and cooling circuits are connected to the manifold or the main supply with aquatherm black system PP grid pipe 16x2 mm or alternative connection systems (e.g. aquatherm grey pipe).

### 4. Installation at the plaster ceiling

Now the ceiling can be plastered with 10 mm plaster covering from top edge of the heating pipe according to manufacturer's instructions. Note that the grids are filled with water and are pressurized while the plasterwork.

Connection systems

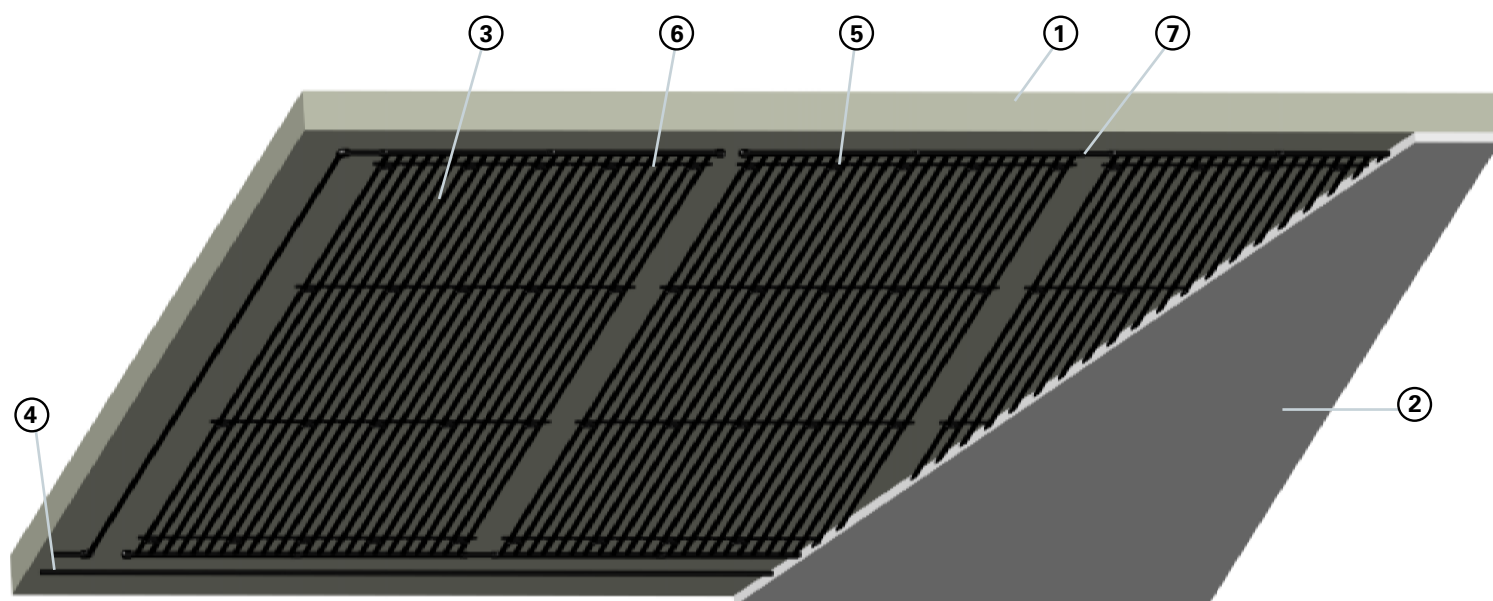
**PLASTER CEILING, DIAGONAL CONNECTION****Recommended type of grid: connection type 50**

- |  |                                       |  |
|--|---------------------------------------|--|
| ① Unfinished surface                               | ④ PP-grid connecting pipe (81006)     | ⑥ Fixing rail for wall heating (81506) |
| ② Plaster  | ⑤ Fixing clamp with wall plug (81298) | ⑦ PP-grid connecting pipe (81006)      |
| ③ aquatherm black system grid (connection type 50) |                                       |  |

**Description**

The aquatherm black system grids for heating and cooling are integrated in a plaster layer directly below the slab.

First the grids, object-related and made to measure, and the connection supply are fixed below the ceiling. Then the ceiling is plastered according to general plastering regulations. All commercial plasters made of gypsum, chalk, concrete and clay are suitable.

**Installation****1. Substructure**

The unfinished surface must be dry and even according to manufacturer's instructions for carrying the plaster. Normally, plaster can be used on all plaster unfinished surfaces. With regard to the adhesion there are differences between the unfinished surfaces. The choice of plaster, the working process and the pretreatment of the unfinished surface have to be adjusted to the local conditions. The check of the unfinished surface by the contractor (fettler) is compulsory acc. to VOB part C, DIN 18350 resp. acc. to VOB, part B, DIN 1961. The tolerances of the height and the inclination of the ground must correspond to DIN 18202. The insulation of modern houses is already made at the outside wall.

Plasterworks should be performed only by specialists with appropriate certificates. The check of the ground conditions for plasterworks is made by the specialist companies.

Depending on the processing (single layer or two-ply) only the thickness of the layer changes for the installation of heating grids.

The ground check of the specialist company is made by

- optical check
- smear test (hand check)
- scraping test (putty)
- moistening test (check, if there are rests of release agent)
- CM-device (measuring of moisture)
- temperature measuring (deep temperatures)

After the ground check the material for pretreatment is selected.

Suitable methods are:

- primer coat
- anti-porosity treatment
- primer
- metallic plaster base (for critical grounds)

Basically the instructions of the plaster manufacturer must be observed.

**2. Installation of the grids**

The grids are connected by heating element socket welding to pairs of grids according to the assembly drawings.

Now the grids, respectively the pairs of grids are fixed with the supplied aquatherm black system fixing clamp with wall plug at the slab according to the layout drawing. The fixing clamp is plugged through the fixing rail, which is mounted spaced in the grids, in the slab. Consider that the fixing clamp with wall plug in connection with the fixing rail can serve as plaster base at the ceiling depending on the plaster base, type and manufacturer. Additional plaster bases in the field of the grids are not required. But in the plaster areas without grids suitable measures have to be carried out. Processing guidelines of the plaster manufacturers must be

observed binding and mandatory. At least four pieces of fixing clamps with wall plug are required per m<sup>2</sup> of installed surface. As the grids have to be fixed even at the ceiling and may not be sagging, more aquatherm black system fixing clamps with wall plug have to be installed for the plaster works. The required number is listed in the table below. The connection of the grids to each other respectively of the grids to the manifold is made with the aquatherm black system PP grid pipe 16 x 2 mm. Even this may be plastered if it has been fixed at the ceiling (e.g. with aquatherm black system plastic fixing clips).

**3. Connection of the grids**

If the aquatherm black system grids are arranged horizontally, the flow can be connected optionally left or right.

For a constant flow the grid areas are always connected diagonally. So the return leaves the grid always opposite the flow.

The maximum area per heating circuit is 15 m<sup>2</sup>.

The maximum area per cooling circuit is described on page 70.

The heating and cooling circuits are connected to the manifold or the main supply with aquatherm black system PP grid pipe 16x2 mm or alternative connection systems (e.g. aquatherm grey pipe).

**4. Installation at the plaster ceiling**

Now the ceiling can be plastered with 10 mm plaster covering from the top edge of the heating pipe according to manufacturer’s instructions. Note that the grids are filled with water and are pressurized during the plasterwork.

**Number of fixing elements with wall plug per grid**

Length of grids	Number of fixing elements with wall plug per grid for a width of					
	up to 24 cm	up to 36 cm	up to 48 cm	up to 60 cm	up to 80 cm	up to 100 cm
up to 140 cm	4	6	8	10	12	14
up to 180 cm	6	9	12	15	18	21
up to 225 cm	8	12	16	20	24	28
up to 275 cm	10	15	20	25	30	35
up to 325 cm	12	18	24	30	36	42
up to 375 cm	14	21	28	35	42	49
up to 425 cm	16	24	32	40	48	56
up to 475 cm	18	27	36	45	54	63
up to 500 cm	20	30	40	50	60	70

### PERFORMANCE VALUE OF PLASTER CEILING

Standard **heating** performance acc. to DIN EN 14037-2

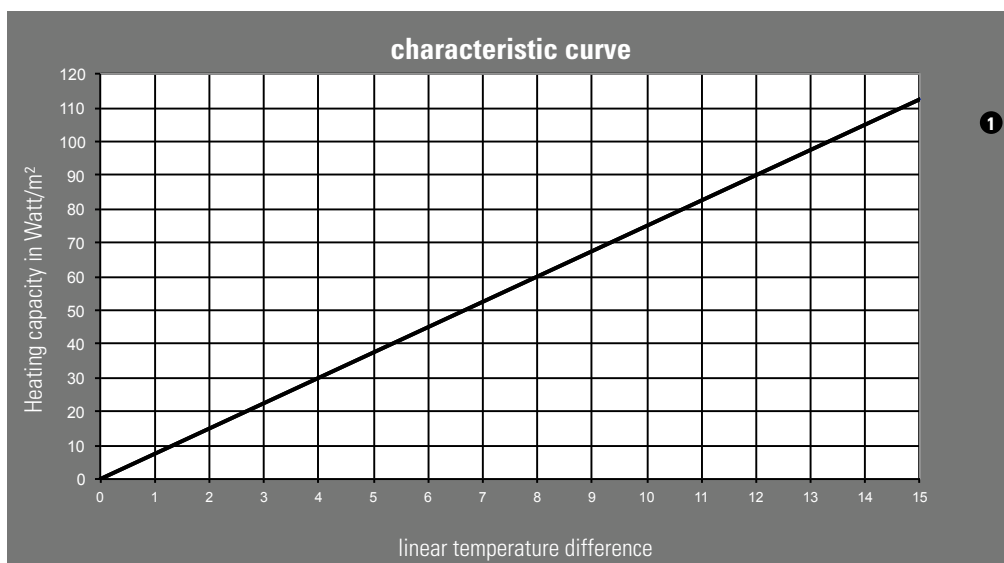

characteristic curve

① Plaster ceiling

Calculation example: Flow temperature 40 °C / Return temperature 35 °C

linear temperature difference K	13,5	15,5	17,5	19,5	22,5	25,5
Room temperature °C	24	22	20	18	15	12
① Plaster ceiling	84	98	111	125	146	167

Standard **cooling** performance acc. to DIN EN 14240: 2004-04

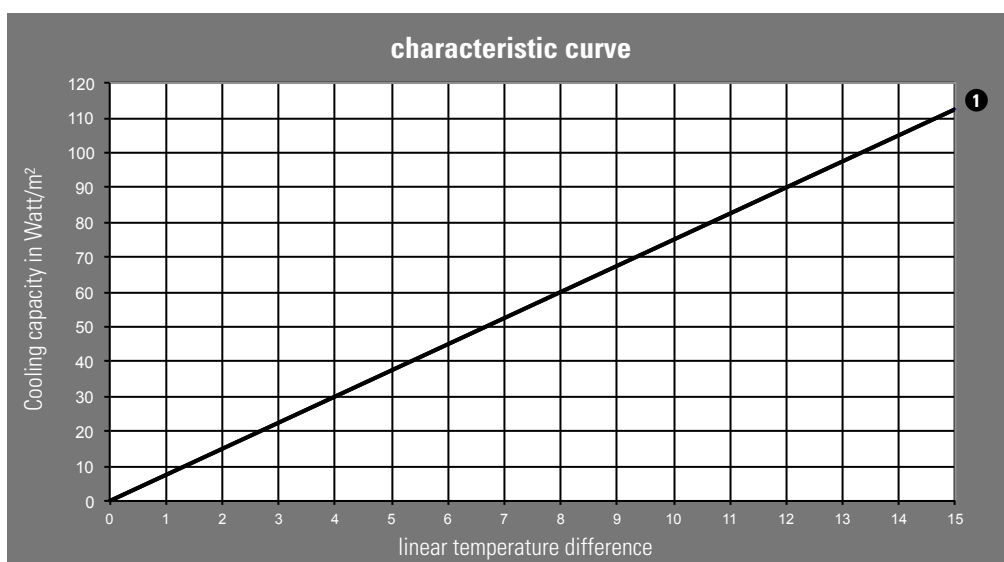

characteristic curve

① Plaster ceiling

Calculation example: Flow temperature 15 °C / Return temperature 17 °C

linear temperature difference K	6	8	10
Room temperature °C	22	24	26
① Plaster ceiling	43	59	75

**DRY CONSTRUCTED WALL WITH GYPSUM PLASTER BOARD, ONE-SIDED CONNECTION**

Recommended type of grid: connection type 64

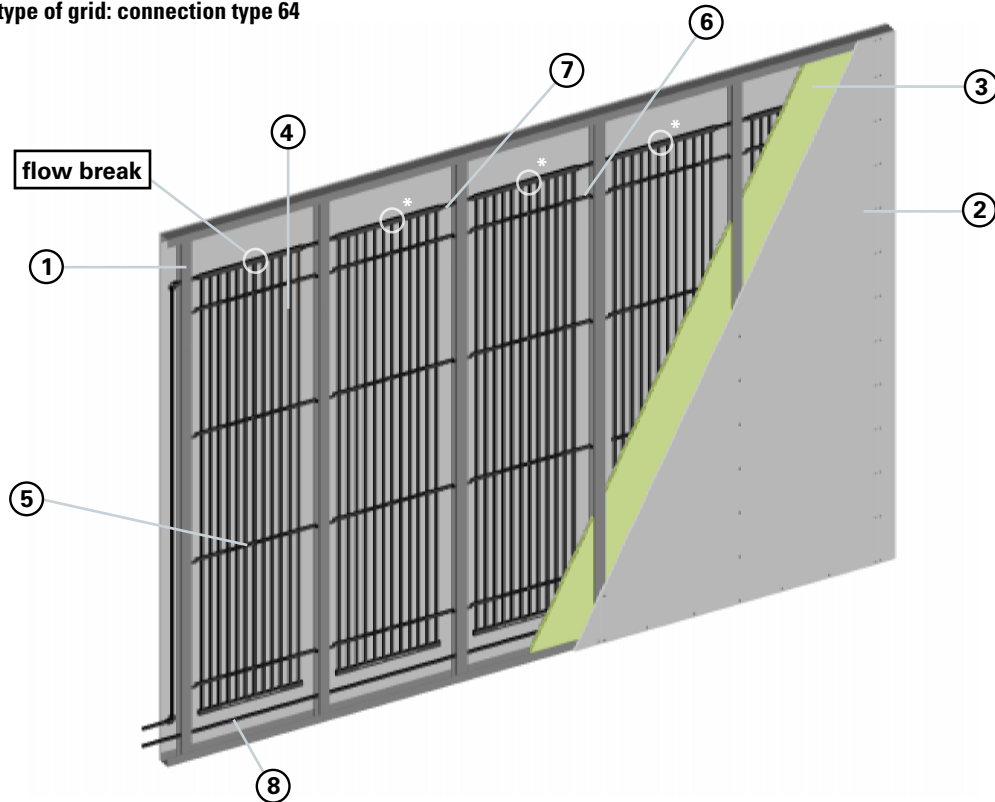

- ① CW profile
- ② Gypsum board
- ③ Insulation
- ④ aquatherm black system-grids (connection type 64) with flow break
- ⑤ Fixing rail (81506)
- ⑥ Fixing rail for dry construction (81297)
- ⑦ One-sided connection (81006)
- ⑧ PP-grid connecting pipe (81026)

**Description**

The aquatherm black system grids for heating and cooling are clamped between in the stud frame of a conventional dry constructed wall. Then the ceiling is covered with gypsum plaster boards, which may have different thermal conductivities.

**Installation**

**1. Substructure**

The stud frame acc. to DIN 18183-1 is constructed corresponding to manufacturer’s instructions. The axis distance of the CW profiles is 625 mm.

**2. Installation of the grids**

The connection pipe of the heating respectively cooling circuits from the manifold or the main supply is fixed in respectively on the floor and directed in the room. The grids, object-related and made to measure, are hung between the CW-profiles according to the layout drawing. Therefore the fixing rail for dry construction is pushed on both sides of the fixing rail at the grid and fixed with the integrated cable tie. The required quantity is described in the table on page 41. Now the fixing rail for dry construction can be screwed sidewise in the CW profile. The end of the fixing rail is pushed with both screwing openings up to the stop respectively flush in or at the CW profile. This is also possible the other way round by screwing first the fixing rail for dry construction in the CW-profile and then hanging the grids in. Now the grids are cased together and connected to the connection pipe.

**3. Connection of the grids**

For the vertical arrangement of aquatherm black system grids the flow is always connected on the top, optionally left or right. The grids of this system have a one-sided socket connection with a forced flow. The grids can be connected one-sided and a constant flow is assured.

After fixing the grids at the CW-profiles they are interconnected to heating respectively cooling areas according to the layout drawing. Therefore the aquatherm black system corrugated pipe from the coil is used, which is separable each 25 cm and can be cut to the required length. The selected pipe is welded with an elbow by heating element socket welding at the grid, laid through the CW-profile and connected with the next grid. For the prevention of damages in the duct area a protective pipe is recommended.

The maximum area per heating circuit is 15 m².

The maximum area per cooling circuit is described on page 70.

The heating and cooling circuits are connected to the manifold or the main supply with aquatherm black system PP grid pipe 16 x 2 mm or alternative connection systems (e.g. aquatherm grey pipe).

**4. Installation at the gypsum plasterboard**

The grid protrudes some millimeters out of the CW-profile. If now the gypsum boards are screwed at the CW-profile according to manufacturer’s instructions, they will press the lightly protruding grids backwards. As the grid cannot be pushed backwards due to the fixing rail for dry construction respectively due to the insulation, there is a contact between the gypsum board and the grid. Both sides of the gypsum plaster board can be covered with grids. Consider that the planking with gypsum plaster board is only single-layer as otherwise the heating- respectively cooling capacity is reduced. Also note that the grids are filled with water and are pressurized during the planking.



Connection systems

## DRY CONSTRUCTED WALL WITH GYPSUM PLASTER BOARD, DIAGONAL CONNECTION

Recommended type of grid: connection type 50

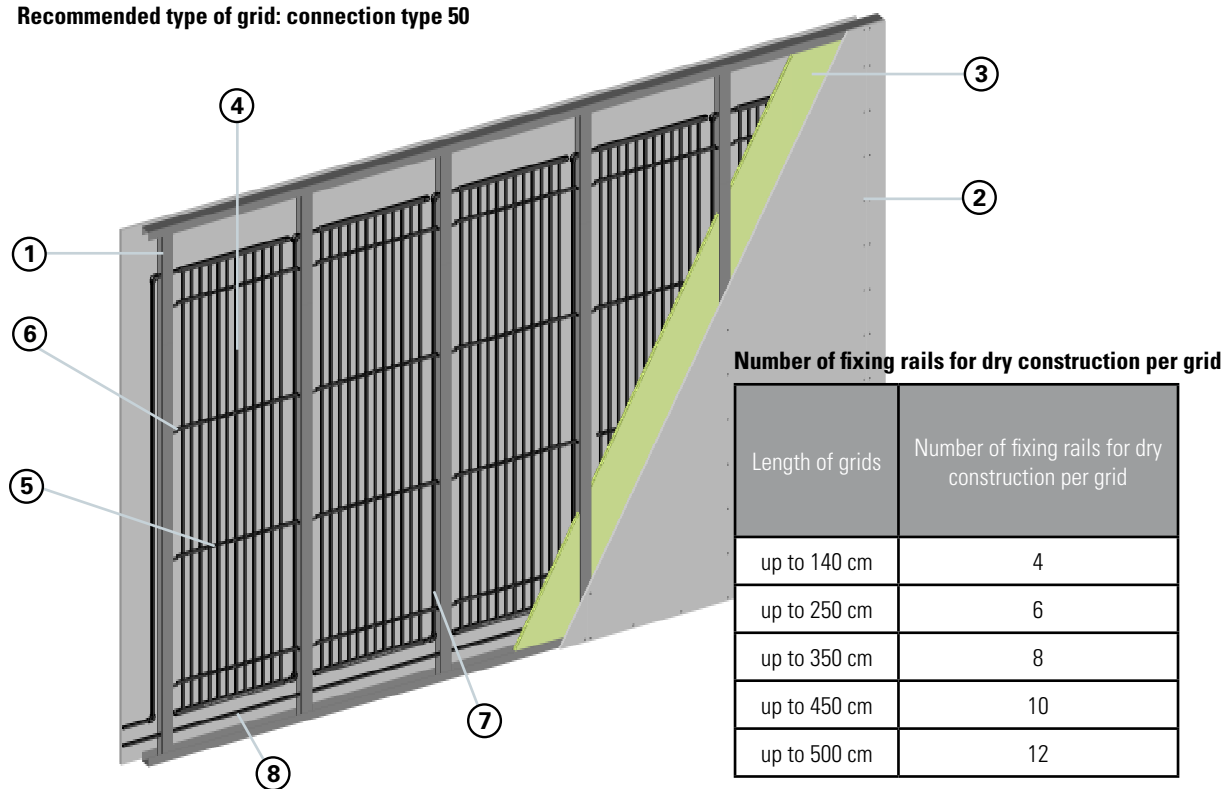

- ① CW profile
- ② Gypsum concrete board
- ③ Insulation
- ④ aquatherm black system-grids (connection type 50)
- ⑤ Fixing rail (81506)
- ⑥ Fixing rail for dry construction (81297)
- ⑦ Diagonal connection (81006)
- ⑧ PP-grid connecting pipe (81026)

### Description

The aquatherm black system grids for heating and cooling are clamped in the stud frame of a conventional dry constructed wall. Then the ceiling is covered with gypsum plaster boards, which may have different thermal conductivities.

### Installation

#### 1. Substructure

The stud frame acc. to DIN 18183-1 is constructed corresponding to manufacturer's instructions. The axis distance of the CW profiles is 625mm.

#### 2. Installation of the grids

The connection pipe of the heating respectively cooling circuits from the manifold or the main supply is fixed in respectively on the floor and directed in the room. The grids, object-related and made to measure, are hung between the CW-profiles according to the layout drawing. Therefore the fixing rail for dry construction is pushed on both sides of the fixing rail at the grid and fixed with the integrated cable tie. The required quantity is described in the table. Now the fixing rail for dry construction can be screwed sidewise in the CW profile. The end of the fixing rail is pushed with both screwing openings up to the stop respectively flush in or at the CW profile. This is also possible the other way round by screwing first the fixing rail for dry construction in the CW-profile and then hanging the grids in. Now the grids are cased together and connected to the connection pipe.

#### 3. Connection of the grids

For the vertical arrangement of aquatherm black system grids the flow is always connected on the top, optionally left or right. The grids areas are

always connected diagonally for a constant flow. So the return leaves the grid always lower, opposite the flow.

After fixing the grids at the CW-profiles they are interconnected to heating respectively cooling areas according to the layout drawing. Therefore the aquatherm black system corrugated pipe from the coil is used, which is separable each 25 cm and can be cut to the required length. The selected pipe is welded with an elbow by heating element socket welding at the grid, laid through the CW-profile and connected with the next grid. For the prevention of damages in the duct area a protective pipe is recommended.

The maximum area per heating circuit is 15 m<sup>2</sup>.

The maximum area per cooling circuit is described on page 70.

The heating and cooling circuits are connected to the manifold or the main supply with aquatherm black system PP grid pipe 16x2mm or alternative connection systems (e.g. aquatherm grey pipe).

#### 4. Installation at the gypsum plasterboard

The grid protrudes some millimeters out of the CW-profile. If now the gypsum boards are screwed at the CW-profile according to manufacturer's instructions, they will press the lightly protruding grids backwards. As the grid cannot be pushed backwards due to the fixing rail for dry construction respectively due to the insulation, there is a contact between the gypsum board and the grid. Both sides of the gypsum plaster board can be covered with grids. Consider that the planking with gypsum plaster board is only single-layer as otherwise the heating- respectively cooling capacity is reduced. Also note that the grids are filled with water and are pressurized during the planking.

Connection systems

## DRY CONSTRUCTED WALL WITH CEMENT BOARD

Recommended type of grid: connection type 56

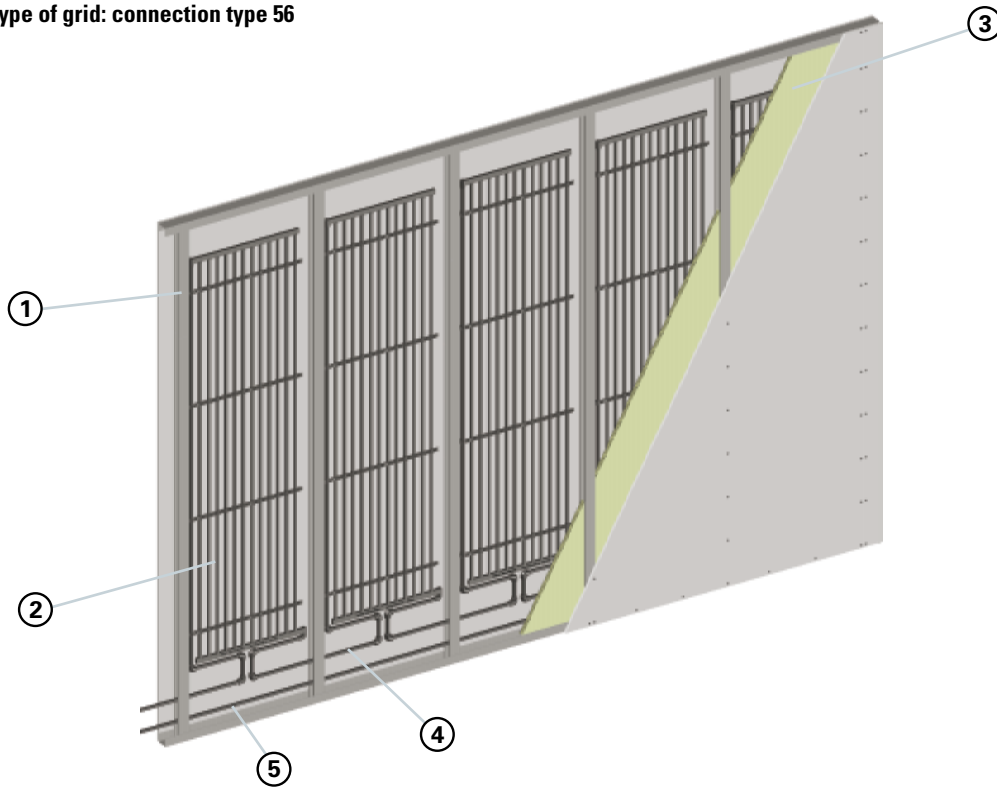

- ① CW profile
- ② aquatherm black system dry wall heating element (connection type 56)
- ③ Insulation
- ④ Corrugated connecting pipe with two elbow outlets (81044)
- ⑤ PP grid connecting pipe (81026)

### Description

The aquatherm black system dry constructed heating elements (even suitable for cooling) are cement boards equipped with already pre-fixed grids and pipes. They are screwed in the stud frame of a conventional dry constructed wall. The elements are supplied with female pipe ends for welded connection or with aquatherm grey pipe-connection.

### Installation

#### 1. Substructure

The stud frame acc. to DIN 18183-1 is constructed corresponding to manufacturer's instructions. The axis distance of the CW profiles is 625 mm.

#### 2. Installation of the grids / cement board

The connection pipe of the heating respectively cooling circuits from the manifold or the main supply is fixed in respectively on the floor and directed in the room. The aquatherm black system dry wall heating elements are screwed at the CW-profiles by the dry wall constructor according to the layout drawing and the manufacturer's instructions. Therefore the supplied 20 cm cement board strip is placed on the floor against the CW-profile. It works as a spacer in the installation opening for the connection to each other and at the connection pipe. The aquatherm black system dry wall element now is placed on this strip and screwed according to manufacturer's instructions with suitable screws at the stud frame. When all aquatherm black system dry wall elements are fixed at the wall, the plumber can connect them. The installation opening and the remaining open surfaces are closed according to manufacturer's instructions with cement boards now. The aquatherm black system dry wall heating elements can even be installed with the connection supply on the top. But note that the flow and return (marked on the connecting ends) are changed. Both sides of the dry wall can be covered with aquatherm

black system dry constructed heating elements. Consider that the planking is only single-layer as otherwise the heating- respectively cooling capacity of the wall is reduced. Also note that the grids are filled with water and are pressurized before closing the installation opening.

#### 3. Connection of the grids

For the vertical arrangement of the aquatherm black system grids the flow is always connected on the top, optionally left or right. For a constant flow the grid areas are always connected diagonally. So the return leaves the grid always lower, opposite the flow.

After fixing the aquatherm black system dry constructed heating elements they are interconnected to heating respectively cooling areas according to the layout drawing.

The aquatherm black system-corrugated connecting pipe with two elbow outlets is installed as a finished element for the design with male end for welded connection. The aquatherm black system corrugated connecting pipe is welded at the male pipe end of the grid by heating element socket welding, laid through the CW-profile and connected with the next grid. For the prevention of damages in the duct area a protective pipe is recommended. aquatherm grey PB-pipe 16x2 mm, PE-RT-pipe 16x2mm or the multi-layer metal composite pipe 16x2.4 mm are suitable for the design with sliding sleeve technology connections. The selected pipe is jointed at the aquatherm grey pipe-elbow end at the grid by sliding-sleeve technique, laid through the CW-profile and connected with the next grid. For the prevention of damages in the duct area a protective pipe is recommended.

The maximum area per heating circuit is 15 m<sup>2</sup>.

The maximum area per cooling circuit is described on page 70.

The heating and cooling circuits are connected to the manifold or the main supply with aquatherm black system PP grid pipe 16x2 mm or alternative connection systems (e.g. aquatherm grey pipe).

### PERFORMANCE VALUE OF DRY WALL

Standard **heating** performance acc. to DIN EN 14037-2

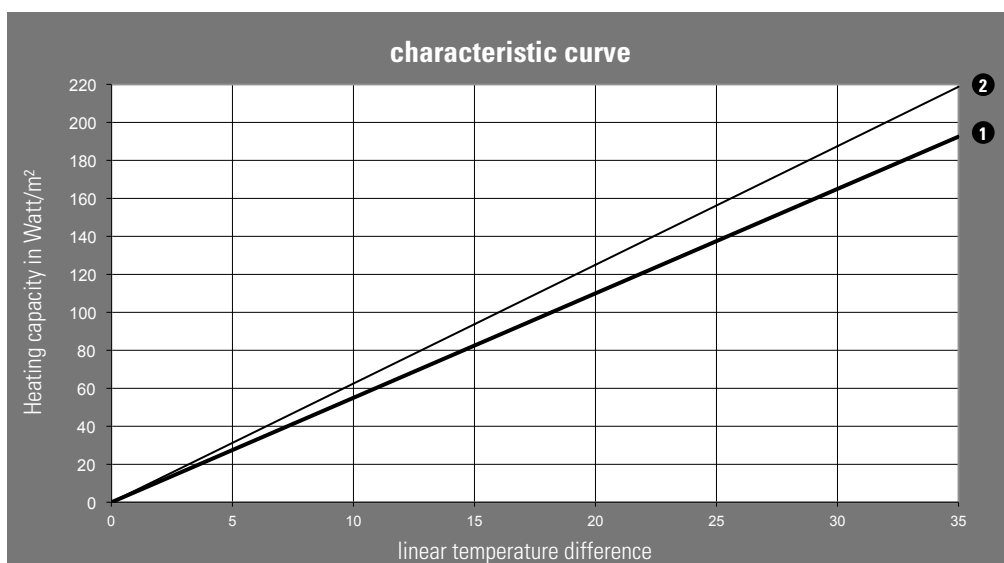

characteristic curve

- 1 Dry wall
- 2 cement board

Calculation example: Flow temperature 40 °C / Return temperature 35 °C

linear temperature difference K	13,5	15,5	17,5	19,5	22,5	25,5
Room temperature °C	24	22	20	18	15	12
1 Dry wall 12,5 mm	69	81	92	103	121	139
2 Cement board	80	93	106	119	138	158

Standard **cooling** performance acc. to DIN EN 14240: 2004-04

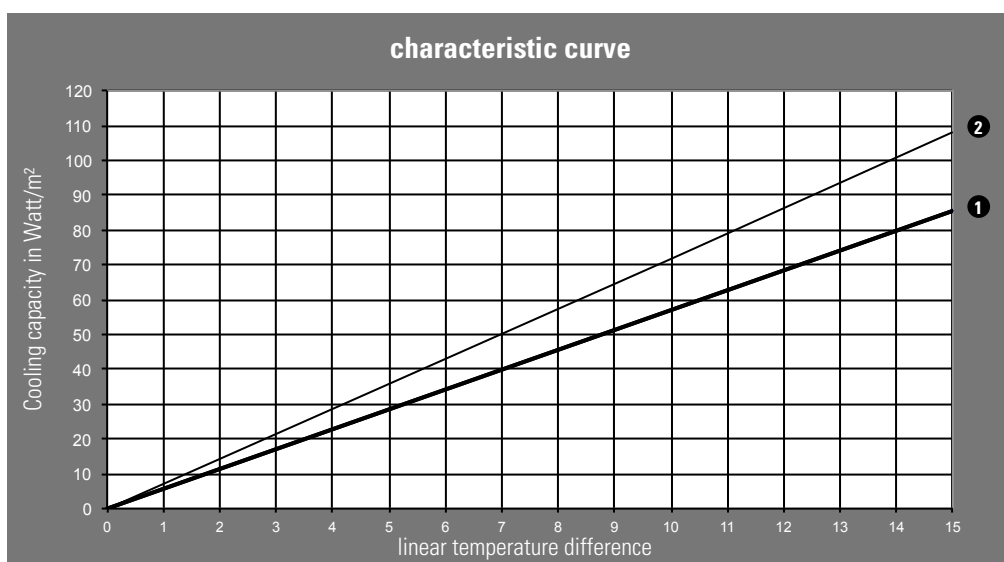

characteristic curve

- 1 Dry wall
- 2 cement board

Calculation example: Flow temperature 15 °C / Return temperature 17 °C

linear temperature difference K	6	8	10
Room temperature °C	22	24	26
1 Dry wall 12,5 mm	29	39	50
2 Cement board	42	57	72

Connection systems

## PLASTER WALL, ONE-SIDED CONNECTION

Recommended type of grid: connection type 64/65

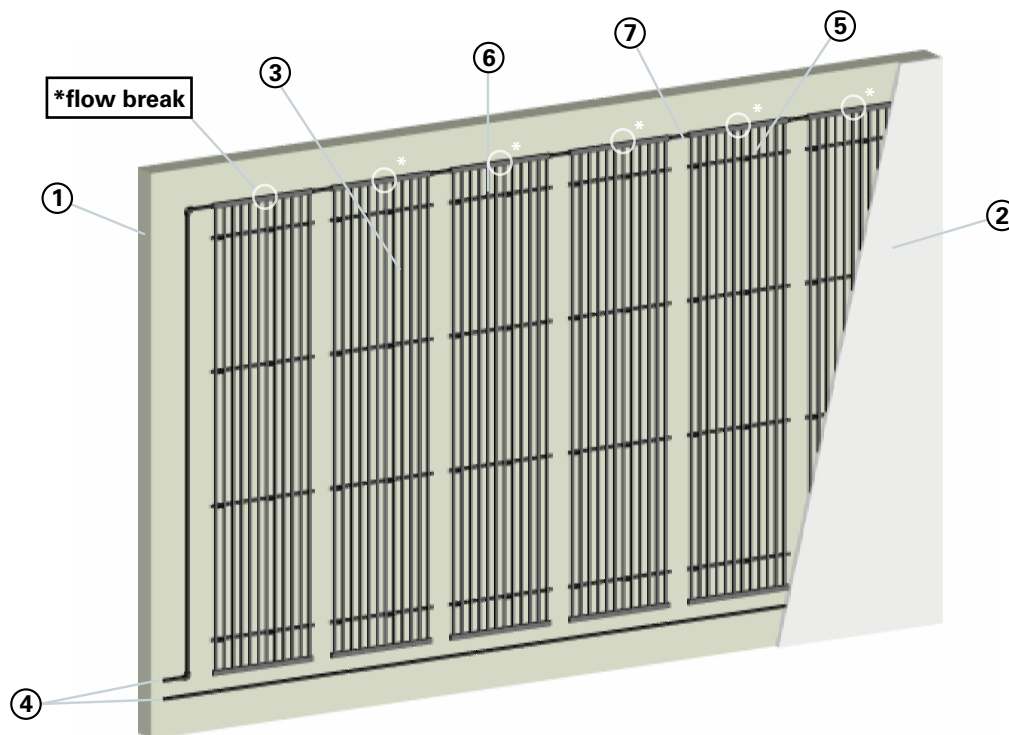

- |   |  |                                       |
|---|--|---------------------------------------|
| ① Unfinished surface  | ④ Connection pipe (81006)              | ⑥ Fixing clamp with wall plug (81298) |
| ② Plaster   | ⑤ Fixing rail for wall heating (81506) | ⑦ One-sided connection (81006)        |
| ③ aquatherm black system-grid (connection type 64/65) with flow break |  |                                       |

### Description

The aquatherm black system grids for heating and cooling are integrated in a plaster layer directly at the wall (prevailing on side wall). First the grids, object-related and made to measure, and the connection supply are fixed at the wall. Then the wall is plastered according to general plastering regulations. All commercial plasters made of gypsum, chalk, concrete and clay are suitable.

### Installation

#### 1. Substructure

The unfinished surface must be dry and even according to manufacturer's instructions for carrying the plaster. Normally, plaster can be used on all plaster unfinished surfaces. With regard to the adhesion there are differences between the unfinished surfaces. The choice of plaster, the working process and the pretreatment of the unfinished surface have to be adjusted to the local conditions. The check of the unfinished surface by the contractor (fettler) is compulsory acc. to VOB part C, DIN 18350 resp. acc. to VOB, part B, DIN 1961. The tolerances of the height and the inclination of the ground must correspond to DIN 18202. The insulation of modern houses is already made at the outside wall.

Plasterworks should be made only by specialists with appropriate certificates. The check of the ground conditions for plasterworks is made by a specialist company. Depending on the processing (single layer or two-ply) only the thickness of the layer changes when installing the heating grids.

The ground check of the specialist company is made by

- optical check
- smear test (hand check)
- scraping test (putty)
- moistening test (check, if there are rests of release agent)

- CM-device (measuring of moisture)
- temperature measuring (deep temperatures)

After the ground check the material for pretreatment is selected. Suitable methods are:

- primer coat
- anti-porosity treatment
- primer
- metallic plaster base (for critical grounds)

Basically the instructions of the plaster manufacturer must be observed.

#### 2. Installation of the grids

The grids can be installed horizontally or vertically. Consider that in case of horizontal installation the flow connection is on the top. Now the grids, respectively the pairs of grids are fixed with the supplied aquatherm black system fixing clamp with wall plug at the wall according to the layout drawing. The fixing clamp is plugged through the fixing rail, which is mounted spaced in the grids, in the wall. Consider that the fixing clamp with wall plug in connection with the fixing rail can serve as plaster base at the wall depending on the plaster base, type and manufacturer. Additional plaster bases in the field of the grids are not required. But in the plaster areas without grids suitable measures have to be carried out. Processing guidelines of the plaster manufacturers must be observed binding and mandatory. At least four pieces of fixing clamps with wall plug are required per m<sup>2</sup> of installed surface. As the grids have to be fixed even at the wall and may not be sagging, more aquatherm black system fixing clamps with wall plug have to be installed for the plaster works.

The required number is listed in the table on page 47. The connection of the grids to each other respectively of the grids to the manifold is made with by

the aquatherm black system PP grid pipe 16x2 mm. After the fixing at the wall (e.g. with aquatherm black system plastic fixing clips) it is plastered.

### **3. Connection of the grids**

If the aquatherm black system grids are arranged vertically, the flow will be connected always on the top, optionally left or right. For this system grids with one-side socket connection with forced flow are applied. That provides a constant flow and the grids can be connected one-sided.

The maximum area per heating circuit is 15 m<sup>2</sup>.

The maximum area per cooling circuit is described on page 70.

The heating and cooling circuits are connected to the manifold or the main supply with aquatherm black system PP grid pipe 16x2 mm or alternative connection systems (e.g. aquatherm grey pipe).

### **4. Installation at the plaster wall**

Now the grids can be plastered according to manufacturer's instructions. Note that the grids are filled with water and pressurized during the plasterwork.

Connection systems

## PLASTER WALL, DIAGONAL CONNECTION

Recommended type of grid: connection type 50

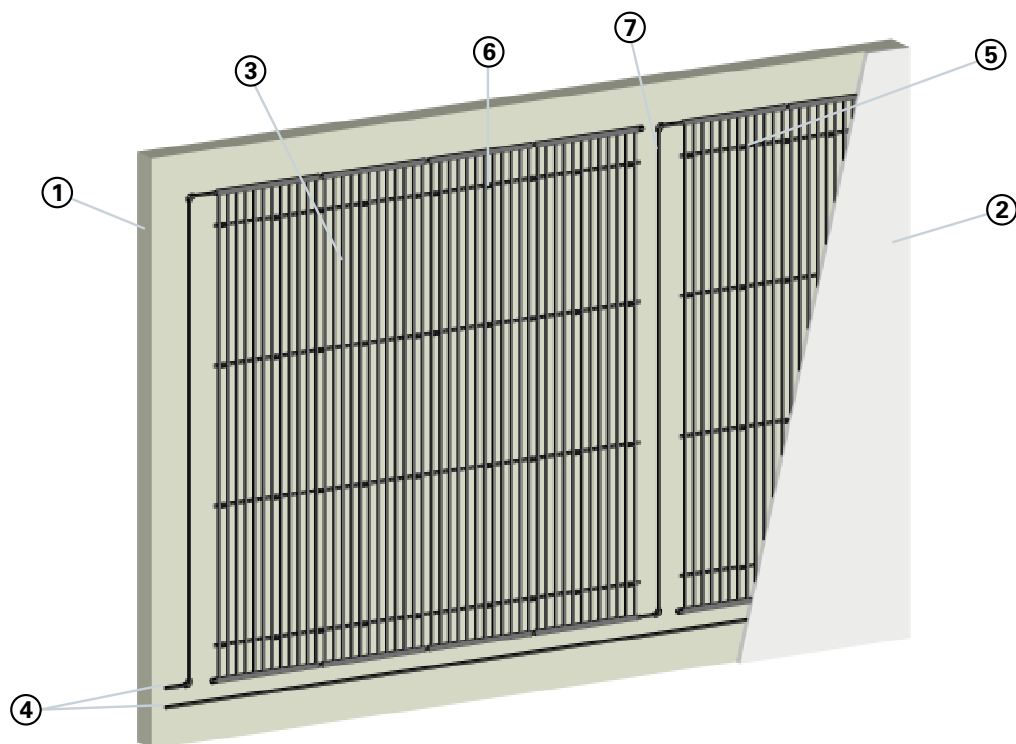

- |  |  |                                       |
|--|--|---------------------------------------|
| ① Unfinished surface                               | ④ Connection pipe (81006)              | ⑥ Fixing clamp with wall plug (81298) |
| ② Plaster  | ⑤ Fixing rail for wall heating (81506) | ⑦ Diagonal connection (81006)         |
| ③ aquatherm black system-grid (connection type 50) |  |                                       |

### Description

The aquatherm black system grids for heating and cooling are integrated in a plaster layer directly at the wall (prevailing outside wall). First the grids, object-related and made to measure, and the connection supply are fixed at the wall. Then the wall is plastered according to general plastering regulations. All commercial plasters made of gypsum, chalk, concrete and clay are suitable.

### Installation

#### 1. Substructure

The unfinished surface must be dry and even according to manufacturer's instructions for carrying the plaster. Normally, plaster can be used on all plaster unfinished surfaces. With regard to the adhesion there are differences between the unfinished surfaces. The choice of plaster, the working process and the pretreatment of the unfinished surface have to be adjusted to the local conditions. The check of the unfinished surface by the contractor (fettler) is compulsory acc. to VOB part C, DIN 18350 resp. acc. to VOB, part B, DIN 1961. The tolerances of the height and the inclination of the ground must correspond to DIN 18202. The insulation of modern houses is already made at the outside wall. Plasterworks should be performed only by specialists with appropriate certificates.

The check of the ground conditions for plasterworks is made by the specialist companies. Depending on the processing (single layer or two-ply) only the thickness of the layer changes when installing the heating grids.

The ground check of the specialist company is made by

- optical check
- smear test (hand check)
- scraping test (putty)
- moistening test (check, if there are rests of release agent)
- CM-device (measuring of moisture)
- temperature measuring (deep temperatures)

After the ground check the material for pretreatment is selected.

- Suitable methods are:
- primer coat
- anti-porosity treatment
- primer
- metallic plaster base (for critical grounds)

Basically the instructions of the plaster manufacturer must be observed.

#### 2. Installation of the grids

The grids are connected by heating element socket welding to pairs of grids according to the assembly drawings. They can be installed horizontally or vertically. Consider that the flow connection is on the top. Now the grids, respectively the pairs of grids, are fixed with the supplied aquatherm black system fixing clamp with wall plug at the wall according to the layout drawing. The fixing clamp is plugged through the fixing rail, which is mounted spaced in the grids, in the wall. Consider that the fixing clamp with wall plug in connection with the fixing rail can serve as plaster base at the wall depending on the plaster base, type and manufacturer. Additional plaster bases in the

field of the grids are not required. But in the plaster areas without grids suitable measures have to be carried out. Processing guidelines of the plaster manufacturers must be observed binding and mandatory. At least four pieces of fixing clamps with wall plug are required per m<sup>2</sup> of installed surface. As the grids have to be fixed even at the wall and may not be sagging, more aquatherm black system fixing clamps with wall plug have to be installed for the plaster works. The required number is listed in the table below.

The connection of the grids to each other respectively of the grids to the manifold is made with the aquatherm black system PP grid pipe 16x2 mm. After the fixing at the wall (e.g. with aquatherm black system plastic fixing clips) it is plastered.

**3. Connection of the grids**

If the aquatherm black system grids are arranged vertically, the flow will be connected always on the top, optionally left or right. For a constant flow the grids are always connected diagonally. Thus the return leaves the grid area always lower, opposite the flow.

The width of the grid pairs is 2.40 m (max. exceeding of 5%)

Further grids or pairs of grids can be connected diagonally now.

The maximum area per heating circuit is 15 m<sup>2</sup>.

The maximum area per cooling circuit is described on page 70.

The heating and cooling circuits are connected to the manifold or the main supply with the aquatherm black system PP grid pipe 16x2 mm or alternative connection systems (e.g. aquatherm grey pipe).

**4. Installation at the gypsum plasterboard**

Now the grids are plastered with 10 cm plaster covering from the top edge of the heating pipe according to manufacturer’s instructions. Note that the grids are filled with water and are pressurized during the plasterwork.

**Number of fixing elements with wall plug per grid**

Length of grids	Number of fixing elements with wall plug per grid for a width of	
	from 24 cm up to 36 cm	from 48 cm up to 100 cm
up to 140 cm	4	8
up to 180 cm	6	12
up to 225 cm	8	16
up to 275 cm	10	20
up to 325 cm	12	24
up to 375 cm	14	28
up to 425 cm	16	32
up to 475 cm	18	36
up to 500 cm	20	40

### PERFORMANCE VALUE OF PLASTER WALL

Standard **heating** performance acc. to DIN EN 14037-2

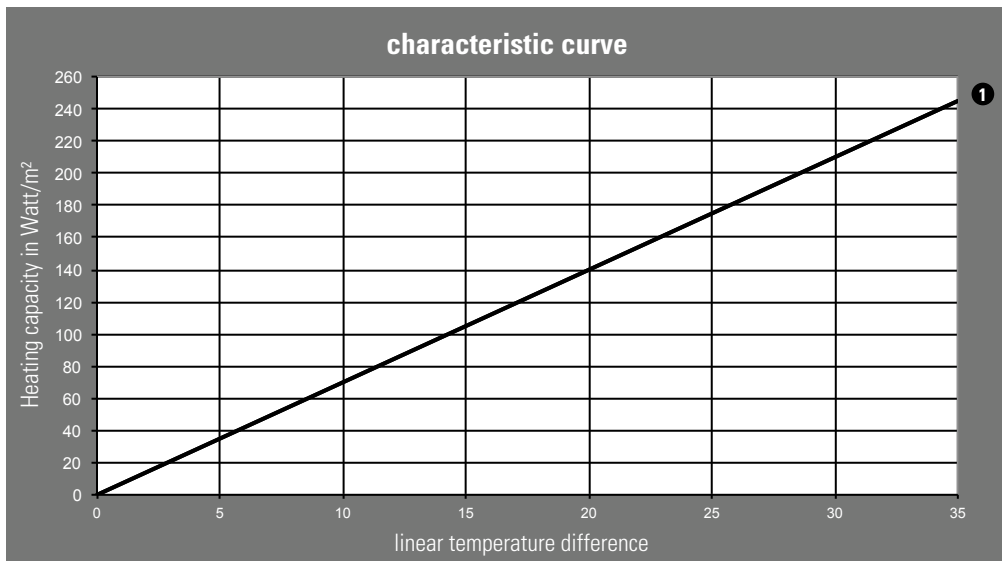

characteristic curve

① Plaster wall

Calculation example: Flow temperature 40 °C / Return temperature 35 °C

linear temperature difference K	13,5	15,5	12,5	19,5	22,5	25,5
Room temperature °C	24	22	20	18	15	12
① Plaster wall	90	105	119	134	156	178

Standard **cooling** performance acc. to DIN EN 14240: 2004-04

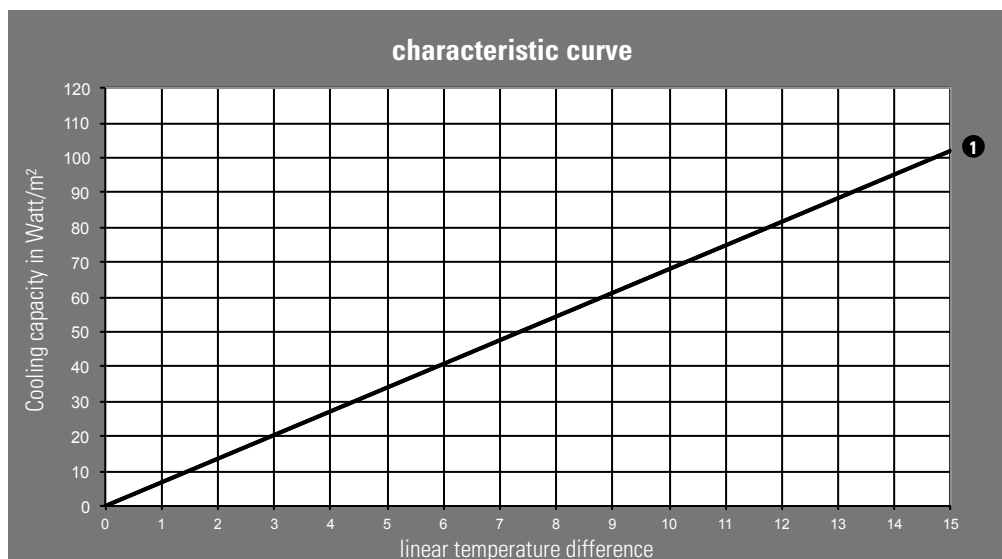

characteristic curve

① Plaster wall

Calculation example: Flow temperature 15 °C / Return temperature 17 °C

linear temperature difference K	6	8	10
Room temperature °C	22	24	26
① Plaster wall	38	51	65





Further fields of application

## HORIZONTAL GRID

### Description

The grids can be installed below window sills, in low wall areas or in curve areas, where a vertical installation is not possible due to rigid manifold pipes. That reduces the number of short respectively slim grids as well as the number of welding connections. Thus difficult areas can be covered with grids fast and efficiently. Note that the grids are connected with the flow on top.



Connection type 50

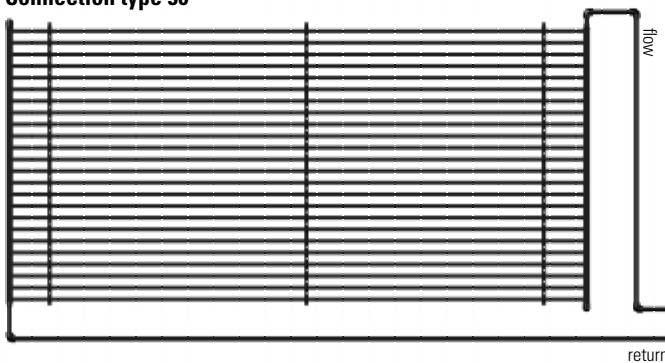

Connection type 64

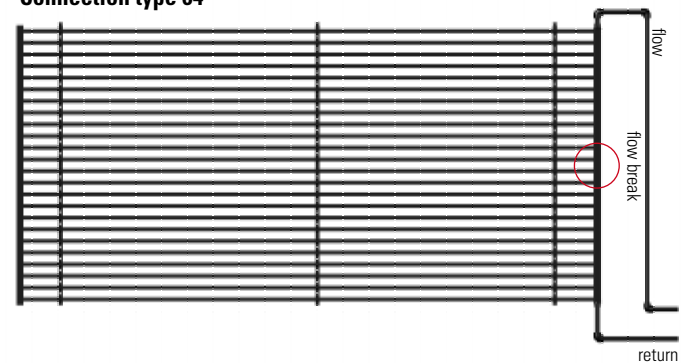

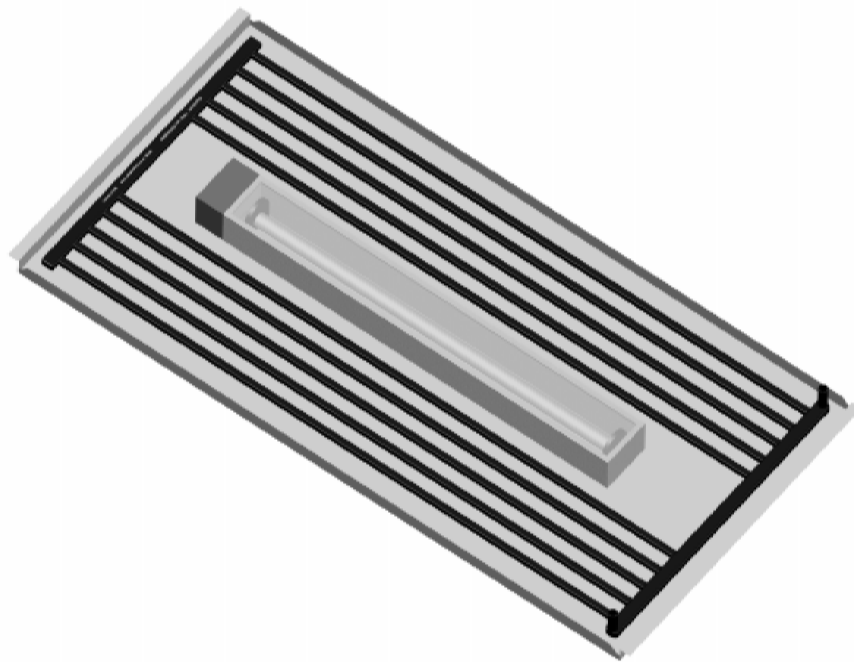

Further fields of application

## **TECHNICAL GRID**

### **Description**

To facilitate the installation of lamps, loudspeakers or sprinklers the grids must be disconnected. Thus one grid is divided into two parts. But this is not possible in metal panel ceilings. For achieving a high covering in spite of this, technical grids are available. Here grid pipes can be left open in the grid factory-provided. This is possible for all types of connection. When ordering please advise that a technical grid is required, as there is no special article-number for this grid. The number and position of the open left grid pipes has to be specified.



Further fields of application

**USE IN THE SHOWER**

**Description**

- › Comfortable warmth in the shower area
- › Simple assembly
- › Individually adjustable to size of shower and shower fitting
- › Applicable in combination with existing radiator system via single room control
- › Suitable for connection to all standard underfloor heating systems
- › Residual heat demand can be covered by it
- › Installation is possible in new and old buildings

Further fields of application

**USE BEHIND THE MIRROR**

**Description**

Non-fogging mirror

- › Thanks to the use of aquatherm black system grids behind the mirror, the warmed mirror cannot be fogged up
- › Simple assembly
- › Individually adjustable to any size of mirror
- › Applicable in combination with existing radiator system through single room control
- › Suitable for connection to all standard underfloor heating systems
- › Perfect addition to the wall heating in showers



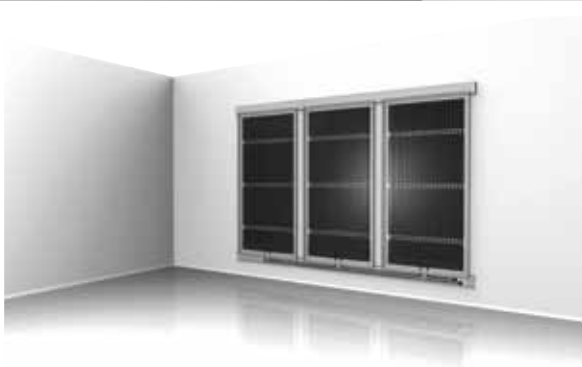

Further fields of application

## H2C-WALL

### Description

Perfect room climate looks as good as this.

Together with aquatherm, HJE Systembau Eickhoff GmbH & Co. KG developed the individually designable air-conditioning system h2c ALUFRAME.CLIMASYSTEM. H2C "hot to cool" stands for an intelligent surface heating and cooling system.

h2c is an air-conditioning and heating system rolled into one. Developed on the basis of the aquatherm black system, the design air-conditioning system is integrated in a textile stretcher and can subsequently be provided on walls or under ceilings. Besides, h2c is also available as detached stand element, for example as partition. The system is connected to the normal heating supply. On the occasion of the EuroShop fair, the h2c ALUFRAME.CLIMASYSTEM has already been honored with the innovation award for architecture and presentation in the category of "products of high architectural quality".

For further information on this system, please visit [www.hje-gruppe.de](http://www.hje-gruppe.de).

### PERFORMANCE VALUE OF H2C-WALL

Standard **heating** performance acc. to DIN EN 14037-2

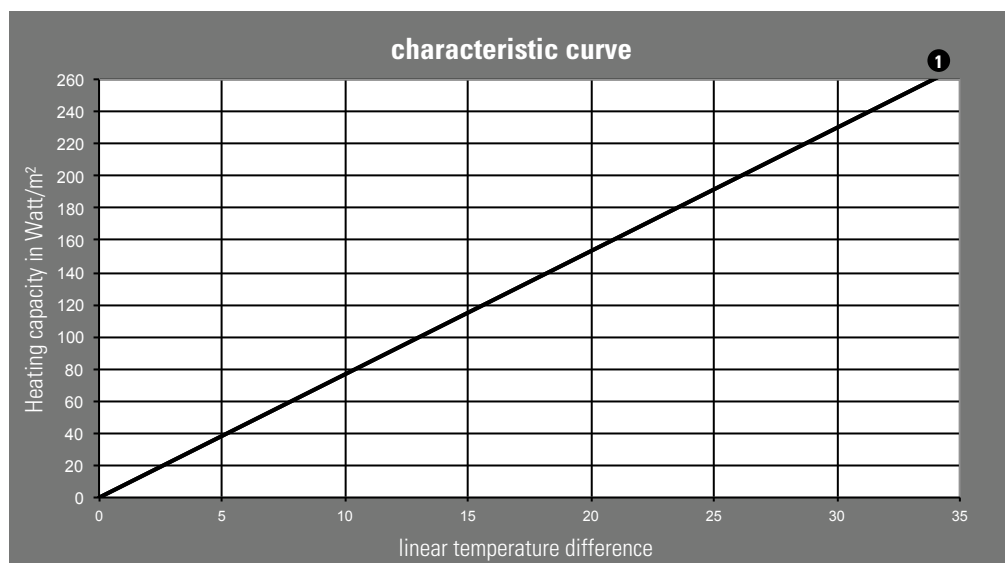

characteristic curve

① H2C-Wall

Calculation example: Flow temperature 40 °C / Return temperature 35 °C

linear temperature difference K	13,5	15,5	17,5	19,5	22,5	25,5
Room temperature °C	24	22	20	18	15	12
① H2C-Wall	102	119	136	154	180	230

Standard **cooling** performance acc. to DIN EN 14240: 2004-04

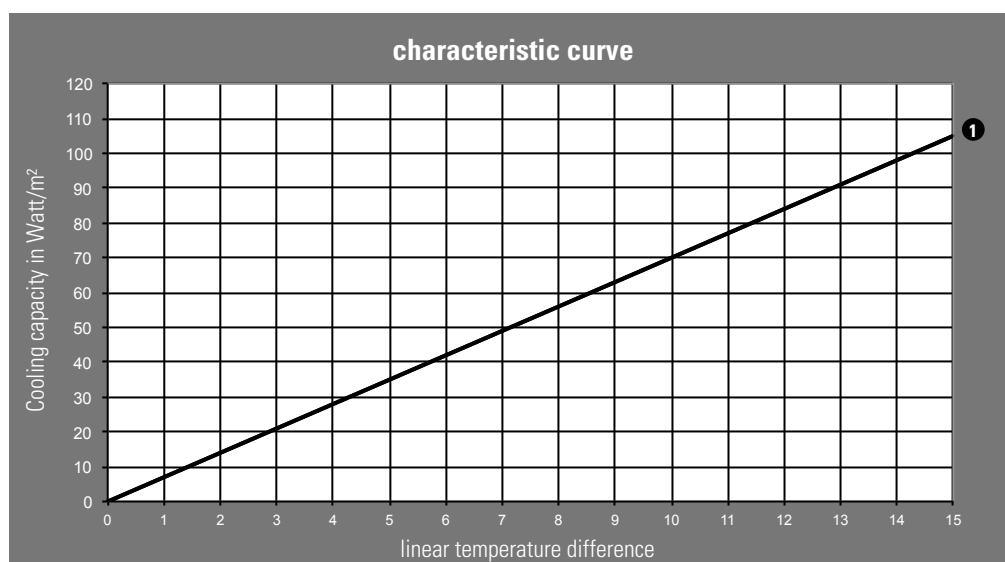

characteristic curve

① H2C-Wall

Calculation example: Flow temperature 15 °C / Return temperature 17 °C

linear temperature difference K	6	8	10
Room temperature °C	22	24	26
① H2C-Wall	39	53	67

Further fields of application

**UNDERFLOOR HEATING**

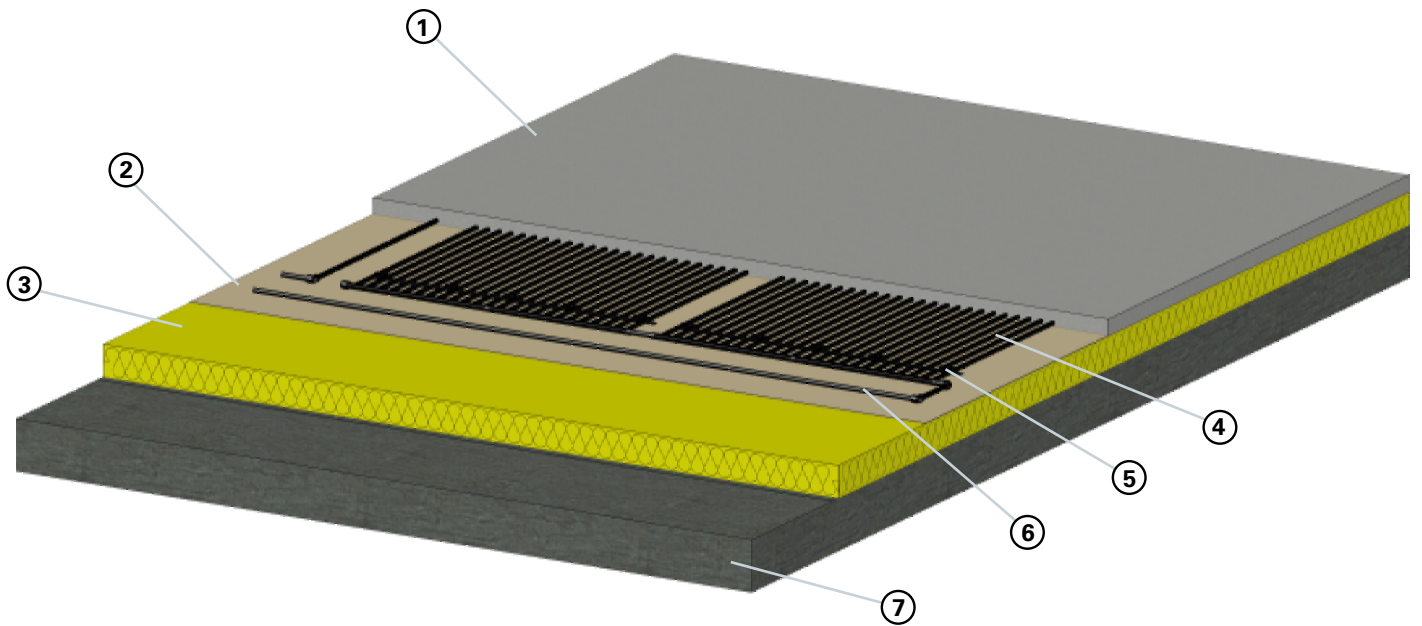

① Screed

② Foil

③ Insulation

④ Grids

⑤ Fixing

⑥ Connecting pipe

⑦ Floor slab

**Description**

The aquatherm black system grids are also suitable for underfloor heating in the screed. The grids are connected side-by-side or diagonally like in the plaster ceiling. To prevent the floating during the screed casting, the grids must be fixed on the insulation. All types of screed, approved for underfloor heating can be applied. The covering depends on the type of screed, but has to be minimum 30 mm from the top edge of the heating pipe.

## CONTROL METHOD

### General description

aquatherm offers a complete system with all necessary components for the best control of a surface heating or cooling. This covers new or old buildings, the connection to existing heating systems as well as small surfaces or big projects.

The individual room control, acc. to EnEV, is obligatory prescribed for surface heating and cooling systems as far as the object is adjusted by it. The individual room control can be left out only if the basic load is covered. Then the peak loads are covered by a separate cooling/heating system with an individual room control.

The room temperature control is recorded by a room thermostat, which is mounted at the wall between 110 cm - 140 cm above the finished floor. Consider that the thermostat is not placed behind curtains or blinds, not in draft and is not exposed to direct solar radiation. The room thermostat switches the actuator when exceeding the temperature in cooling operation and when undercutting the temperature in heating operation of the preset temperature. The actuator closes resp. opens the control valve.

In systems that are heated and cooled, the thermostat is changed by an automatic change-over signal into the required mode. If the surface temperature in the ceiling or wall of the installed system is in cooling operation below the dew-point, condensation at the surface might appear. This can be avoided by different alternatives.

### Break of the volume flow

Dew-point sensors, permanently controlling the condensation, can be applied at critical places, e. g. at cold water flow and or near to a window. If condensate is formed, it will be directly reported to the room thermostat or the convertor. The cooling area is closed at once and there is no more condensation. In this time the cooling ceiling has no output. The zone opens as soon as the water at the dew-point sensor is evaporated.

### Adjustment of the flow temperature

But if the output of the cooling ceiling should not be interrupted it will be possible to control the flow temperature depending of the dew-point temperature of reference rooms. A control continuously figures the dew-point with a humidity and temperature sensor. Thus the flow temperature is kept permanently 0.5 K up to 1.0 K over the critical temperature. No forming of condensation in the room.

Additionally to the above mentioned solutions the supply of humid air into the room through open windows can be controlled. The signal "open window" has to be integrated in the selected control.

**CONTROL METHOD**

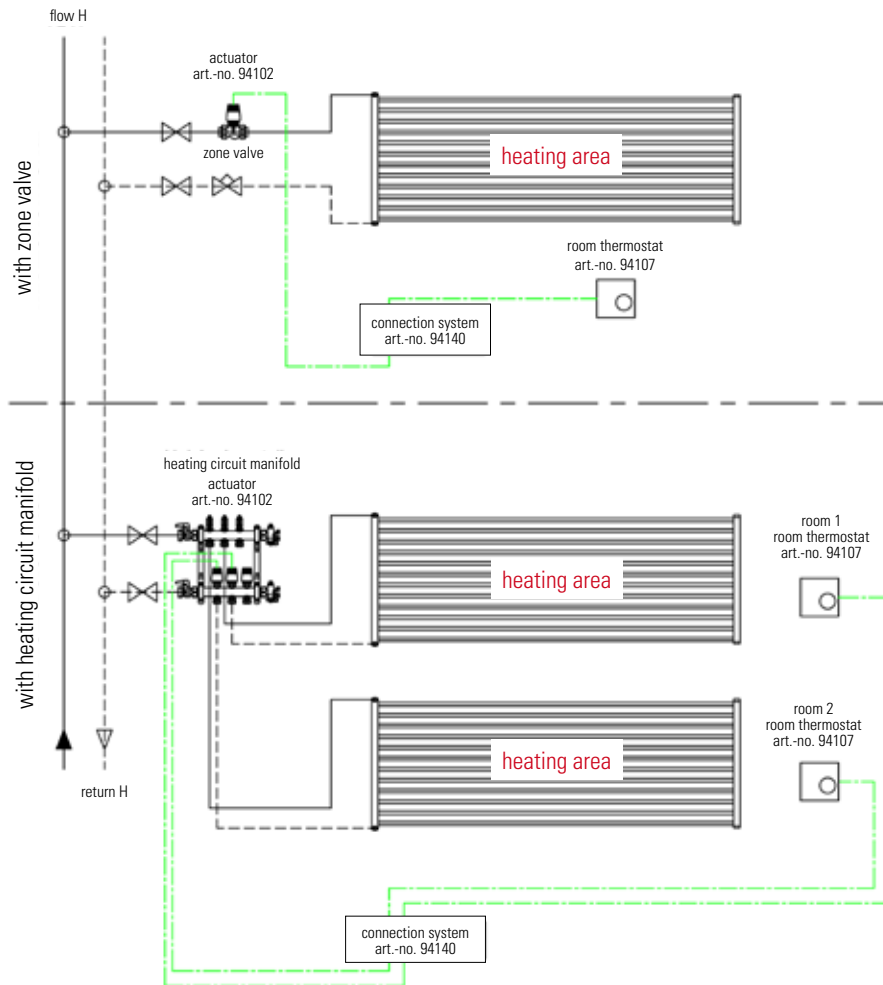

**Individual room control heating with room thermostat Art.-No. 94107 in a two-pipe system, operating voltage: 230 V**

The individual room control heating in a two-pipe system is adjusted by a room thermostat. This is switched by an actuator on a connection system to facilitate the allocation of the components. Depending on the design of the connection system 6 to 14 room thermostats can be connected.

Optionally zone valves for individual rooms or heating circuit manifolds can be installed. Consider the system voltage when selecting the components.



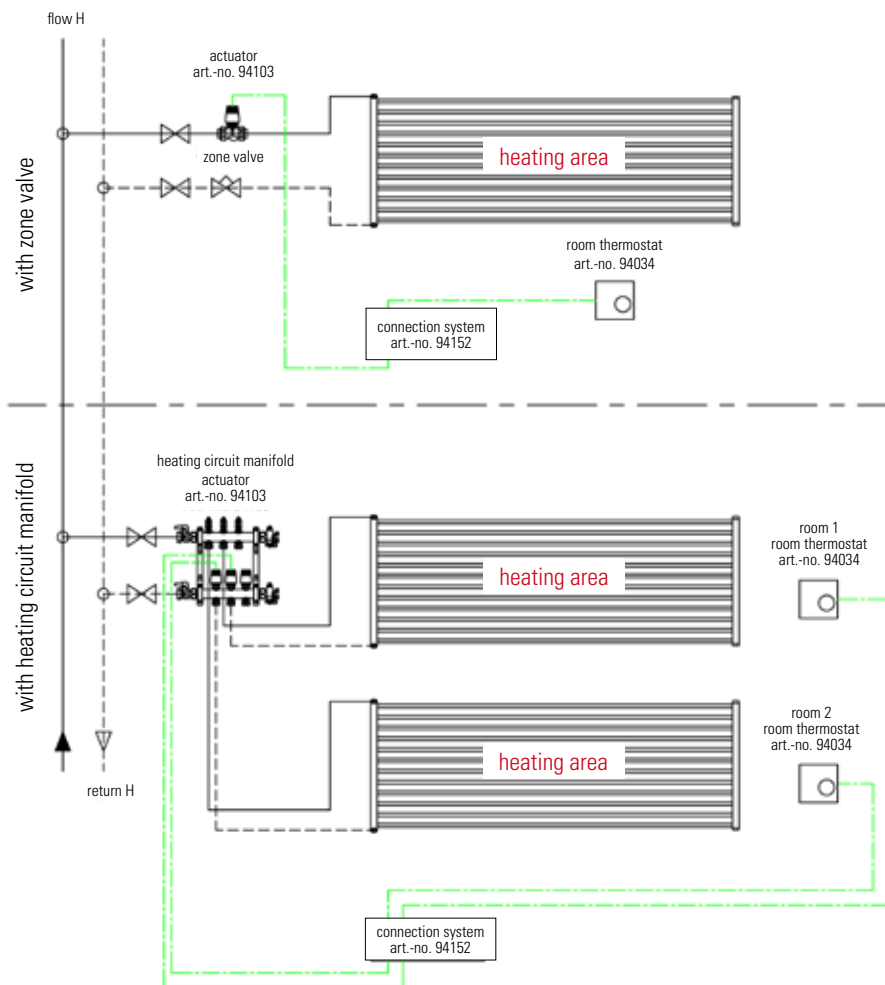

**Individual room control heating with room thermostat Art.-No. 94034 in a two-pipe system, operating voltage: 24 V**

The individual room control heating in a two-pipe system is adjusted by a room thermostat. This is switched by an actuator on a connection system to facilitate the allocation of the components.

If the thermostat, like in this case, is provided for several loading cases (heating or cooling), this must be considered when wiring.

Depending on the design of the connection system up to 6 room thermostats and 14 actuators can be connected. Optionally zone valves for individual rooms or heating circuit manifolds can be installed. Consider the system voltage when selecting the components.

**CONTROL METHOD**

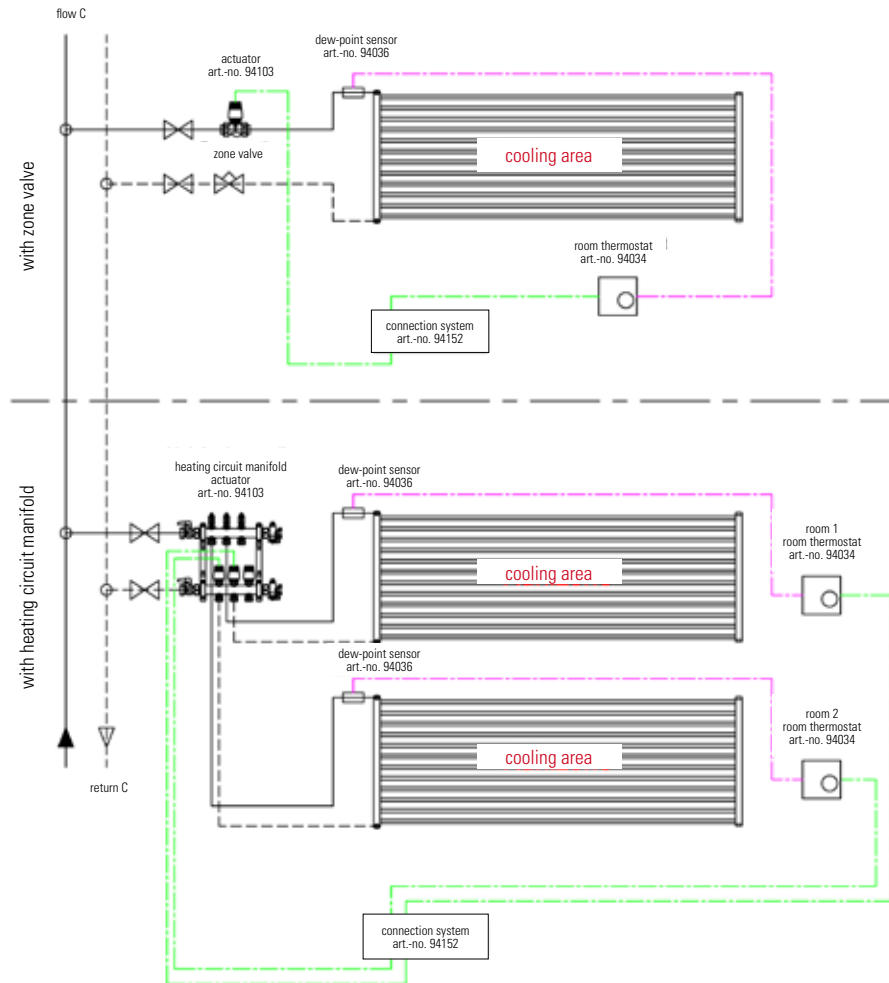

**Individual room control cooling with room thermostat Art.-No. 94034 in a two-pipe system, operating voltage: 24 V**

The individual room control cooling in a two pipe system is adjusted by a room thermostat. This is switched by an actuator on a connection system to facilitate the allocation of the components.

If the thermostat, like in this case, is provided for several loading cases (heating or cooling) this must be considered when wiring.

Depending on the design of the connection system 6 room thermostats and 14 actuators can be connected. For avoiding a condensation a dew-point sensor is connected to a flow pipe in the room. The dew-point sensor consists of a flexible film with a strip line design. The film is fixed at the flow pipe in a way that the strip lines are exposed to the ambient air and the back of the film is connected thermally close to the pipe. At a relative humidity between 80-85%, the sensor achieves a selected resistance value, which releases a switching operation of the connected control. The dew-point sensor is connected directly on the room thermostat. If now a switching operation of the dew-point sensor arrives at the room thermostat, it will switch off all connected actuators and the zone is closed.

Optionally zone valves for individual rooms or heating circuit manifolds can be installed. Consider the system voltage when selecting the components.

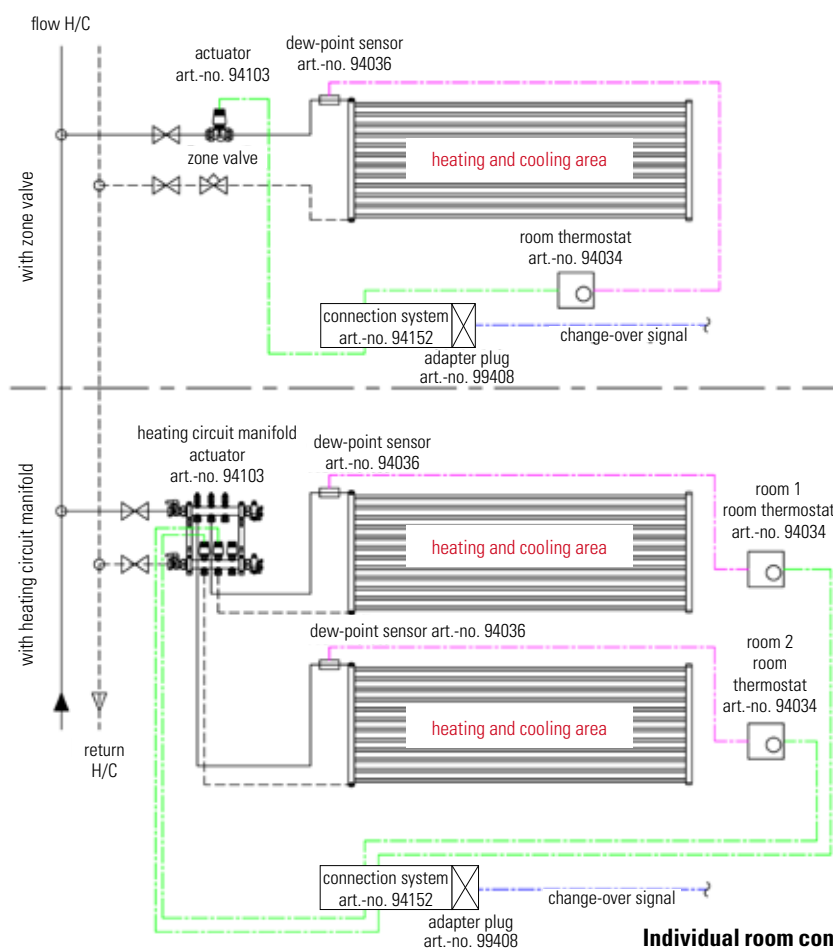

**Individual room control heating/cooling with room thermostat Art.-No. 94034 in a two-pipe system, operating voltage: 24 V**

The individual room control heating/cooling in a two-pipe system is adjusted by a room thermostat. This is switched by an actuator on a connection system to facilitate the allocation of the components.

If the thermostat, like in this case, is provided for several loading cases (heating or cooling) this must be considered when wiring.

Depending on the design of the connection system 6 room thermostats and 14 actuators can be connected. For avoiding a condensation a dew-point sensor is connected to a flow pipe in the room. The dew-point sensor consists of a flexible film with a strip line design. The film is fixed at the flow pipe in a way that the strip lines are exposed to the ambient air and the back of the film is connected thermally close to the pipe. At a relative humidity between 80-85%, the sensor achieves a selected resistance value, which releases a switching operation of the connected control. The dew-point sensor is connected directly on the room thermostat. If now a switching operation of the dew-point sensor arrives at the room thermostat, it will switch off all connected actuators and the zone is closed. An adapter plug is plugged on the connection system. That is essential for processing the external change-over signal. If there are several connection systems with adapter plug in one building, the adapter plugs can be connected in series to distribute the change-over signal in the whole building. By means of the change-over signal the room thermostats will be informed if the flow is streamed with cool or hot water. Depending on the case the room temperature set point, adjusted at the room thermostat, is noticed as superior or lower limit.

Optionally zone valves for individual rooms or heating circuit manifolds can be installed. Consider the system voltage when selecting the components.

**CONTROL METHOD**

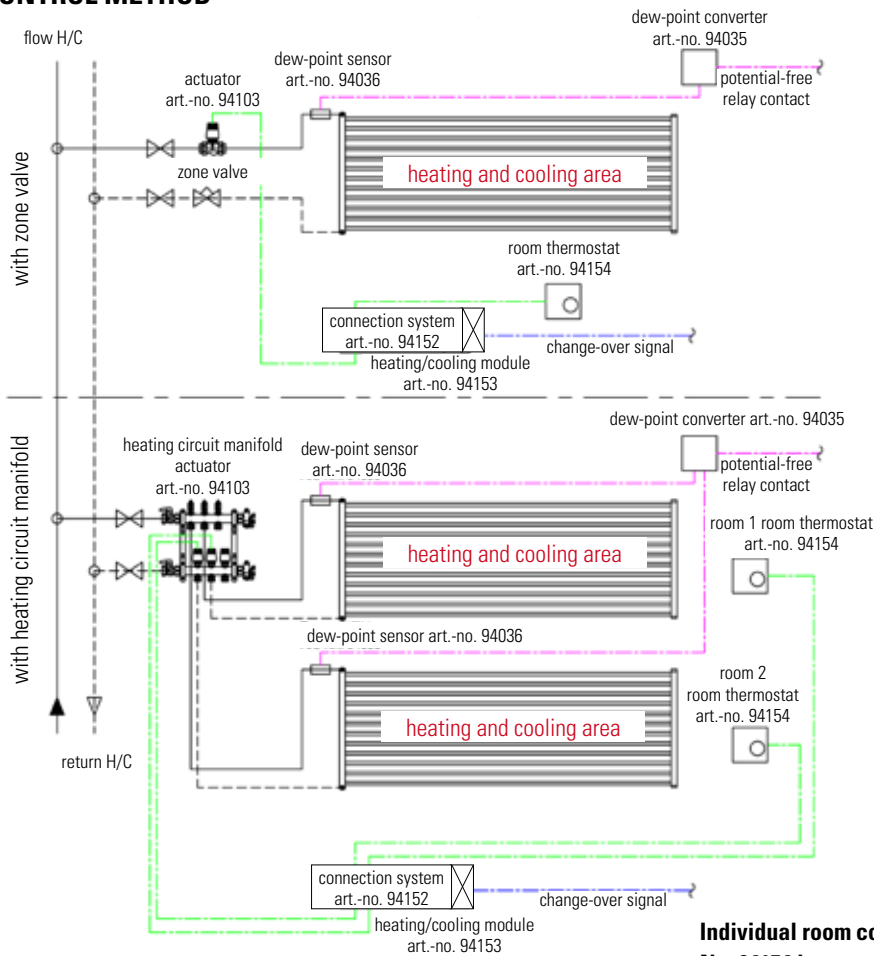

**Individual room control heating/cooling with room thermostat Art.-No. 94154 in a two-pipe system, operating voltage: 24 V**

The individual room control heating/cooling in a two-pipe system is adjusted by a room thermostat. This is switched by an actuator on a connection system to facilitate the allocation of the components.

If the thermostat, like in this case, is provided for several loading cases (heating or cooling) this must be considered when wiring.

Depending on the design of the connection system 6 room thermostats and 14 actuators can be connected. For avoiding a condensation a dew-point sensor is connected to a flow pipe in the room. The dew-point sensor consists of a flexible film with a strip line design. The film is fixed at the flow pipe in a way that the strip lines are exposed to the ambient air and the back of the film is connected thermally close to the pipe. At a relative humidity between 80-85%, the sensor achieves a selected resistance value, which releases a switching operation of the connected control. The dew-point sensor is connected directly on the dew-point converter. 5 dew-point sensors can be connected in parallel. If now a switching operation of the dew-point sensor arrives at the dew-point converter, a cooling aggregate can be switched on or off by a potential-free relay contact or a mixer/valve can be closed. A heating/cooling module is plugged on the connection system. That is essential for processing the external change-over signal. If there are several connection systems with heating/cooling module in one building, the heating/cooling modules can be connected in series to distribute the change-over signal in the whole building. By means of the change-over signal the room thermostats will be informed if the flow is streamed with cool or hot water. Depending on the case the room temperature set point, adjusted at the room thermostat, is noticed as superior or lower limit.

Optionally zone valves for individual rooms or heating circuit manifolds can be installed. Consider the system voltage when selecting the components.

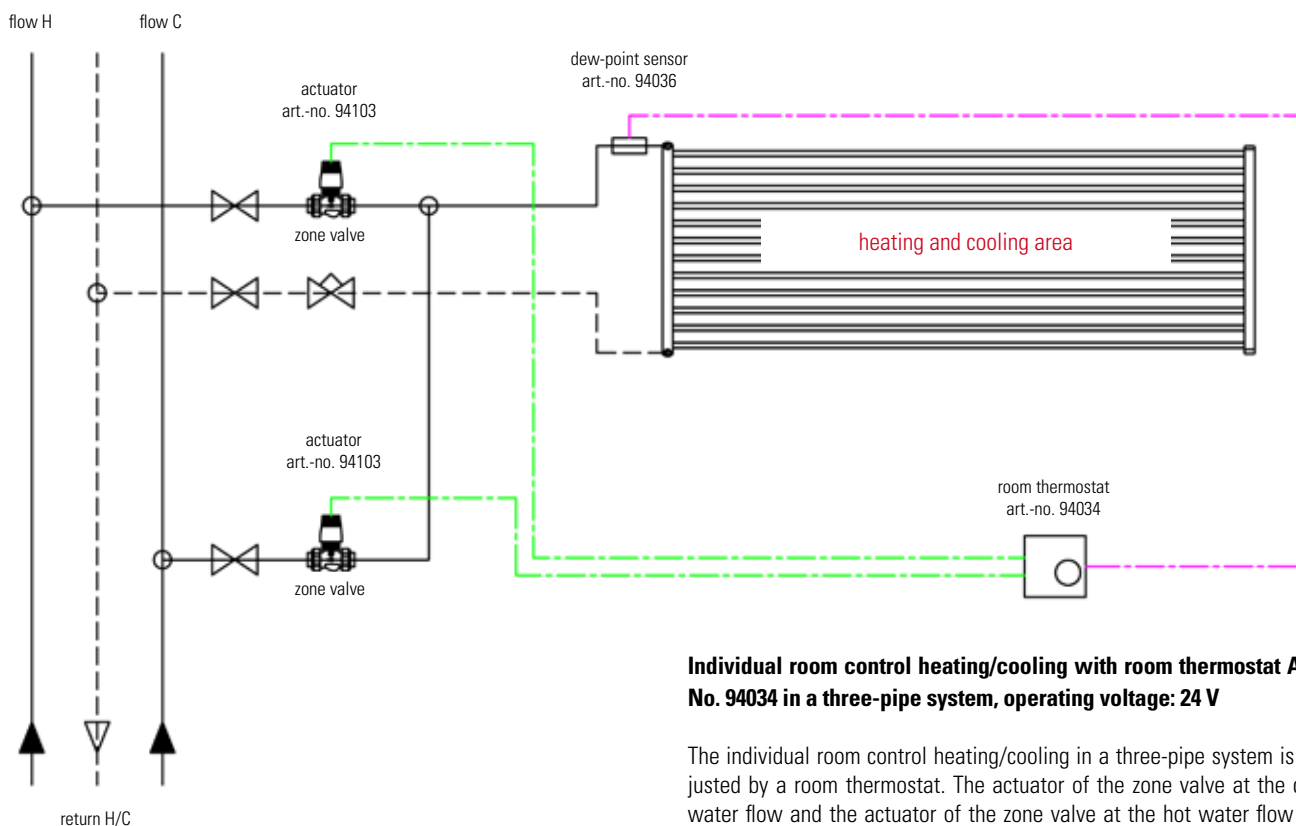

**Individual room control heating/cooling with room thermostat Art.-No. 94034 in a three-pipe system, operating voltage: 24 V**

The individual room control heating/cooling in a three-pipe system is adjusted by a room thermostat. The actuator of the zone valve at the cold water flow and the actuator of the zone valve at the hot water flow are switched on the thermostat.

If the thermostat, like in this case, is provided for several loading cases (heating or cooling) this must be considered when wiring.

For avoiding a condensation a dew-point sensor is connected to a flow pipe in the room. The dew-point sensor consists of a flexible film with a strip line design. The film is fixed at the flow pipe in a way that the strip lines are exposed to the ambient air and the back of the film is connected thermally close to the pipe. At a relative humidity between 80-85%, the sensor achieves a selected resistance value, which releases a switching operation of the connected control. The dew-point sensor is connected directly on the room thermostat. If now a switching operation of the dew-point sensor arrives at the room thermostat, it will switch off all connected actuators and the zone is closed.

A NTC-semiconductor, integrated in the room thermostat, measures the room temperature.

When exceeding the preset set point the actuator for the cooling water flow is opened and when undercut the set point the heating water flow is opened. Consider the system voltage when selecting the components.

**CONTROL METHOD**

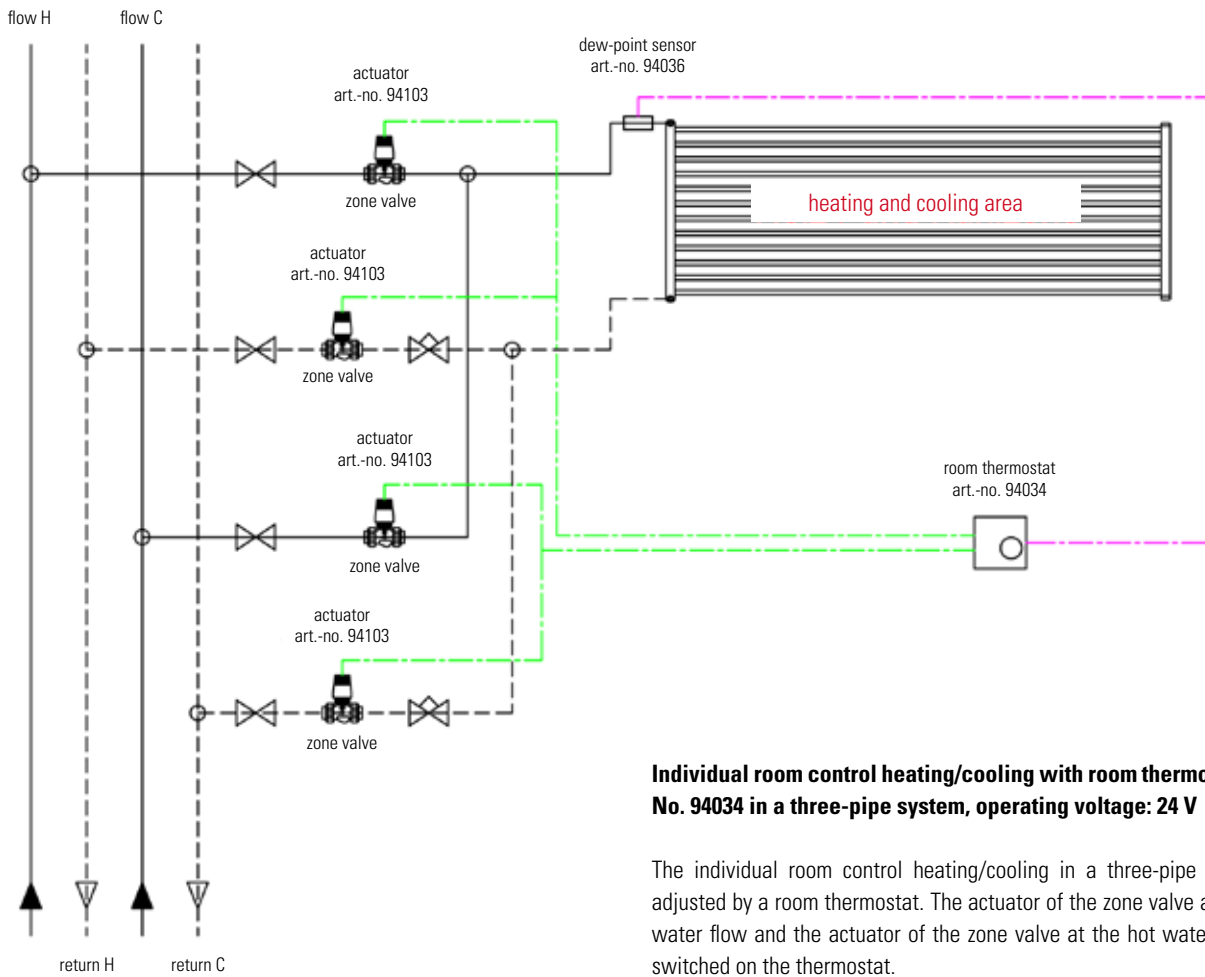

**Individual room control heating/cooling with room thermostat Art.-No. 94034 in a three-pipe system, operating voltage: 24 V**

The individual room control heating/cooling in a three-pipe system is adjusted by a room thermostat. The actuator of the zone valve at the cold water flow and the actuator of the zone valve at the hot water flow are switched on the thermostat.

If the thermostat, like in this case, is provided for several loading cases (heating or cooling) this must be considered when wiring.

For avoiding a condensation a dew-point sensor is connected to a flow pipe in the room. The dew-point sensor consists of a flexible film with a strip line design. The film is fixed at the flow pipe in a way that the strip lines are exposed to the ambient air and the back of the film is connected thermally close to the pipe. At a relative humidity between 80-85%, the sensor achieves a selected resistance value, which releases a switching operation of the connected control. The dew-point sensor is connected directly on the room thermostat. If now a switching operation of the dew-point sensor arrives at the room thermostat, it will switch off all connected actuators and the zone will be closed.

A NTC-semiconductor, integrated in the room thermostat, measures the room temperature.

When exceeding the preset set point the actuator for the cooling water flow is opened and when undercut the set point the heating water flow is opened. Consider the system voltage when selecting the components.

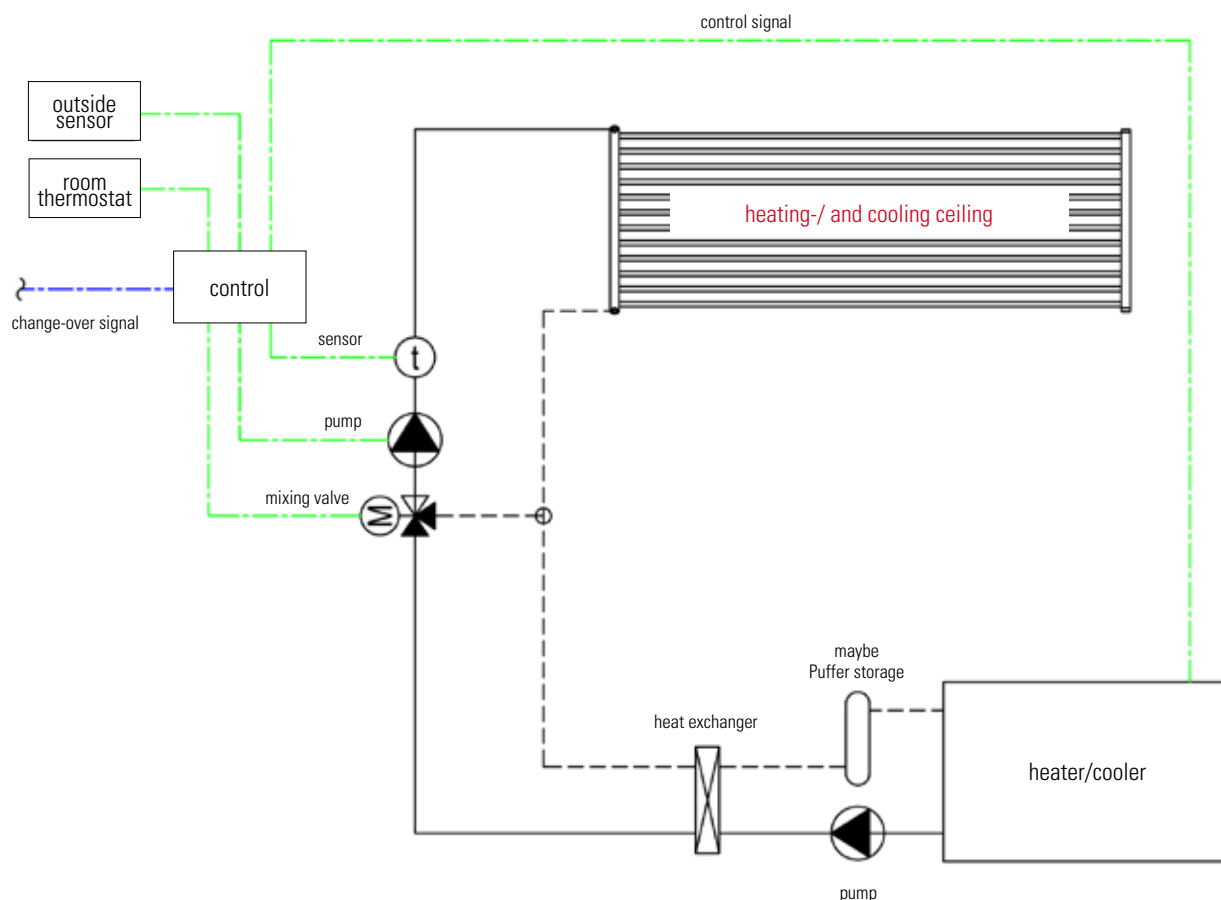

**Control scheme heating/cooling with a heater/cooler in a two-pipe system**

The control scheme charts the generation of hot and cold water by a generator in a two-pipe system. If the generator is placed outdoor it will be required to separate the primary circuit with anti-freezer by a heat exchanger from the secondary circuit. For a better energetic and economic efficiency of the generator a buffer storage, where required, will be used, if it is not still part of the generator. The flow temperature control, controlled by weather conditions, is operated by a programmable control (not subject of the aquatherm product range). The control switching from heating to cooling or reverse is made by the outside sensor or another parameter. It is lead by a control signal to the generator. At the same time a change-over signal is given, with which the connected room thermostats in the control zones can be switched to heating or cooling.

**CONTROL METHOD**

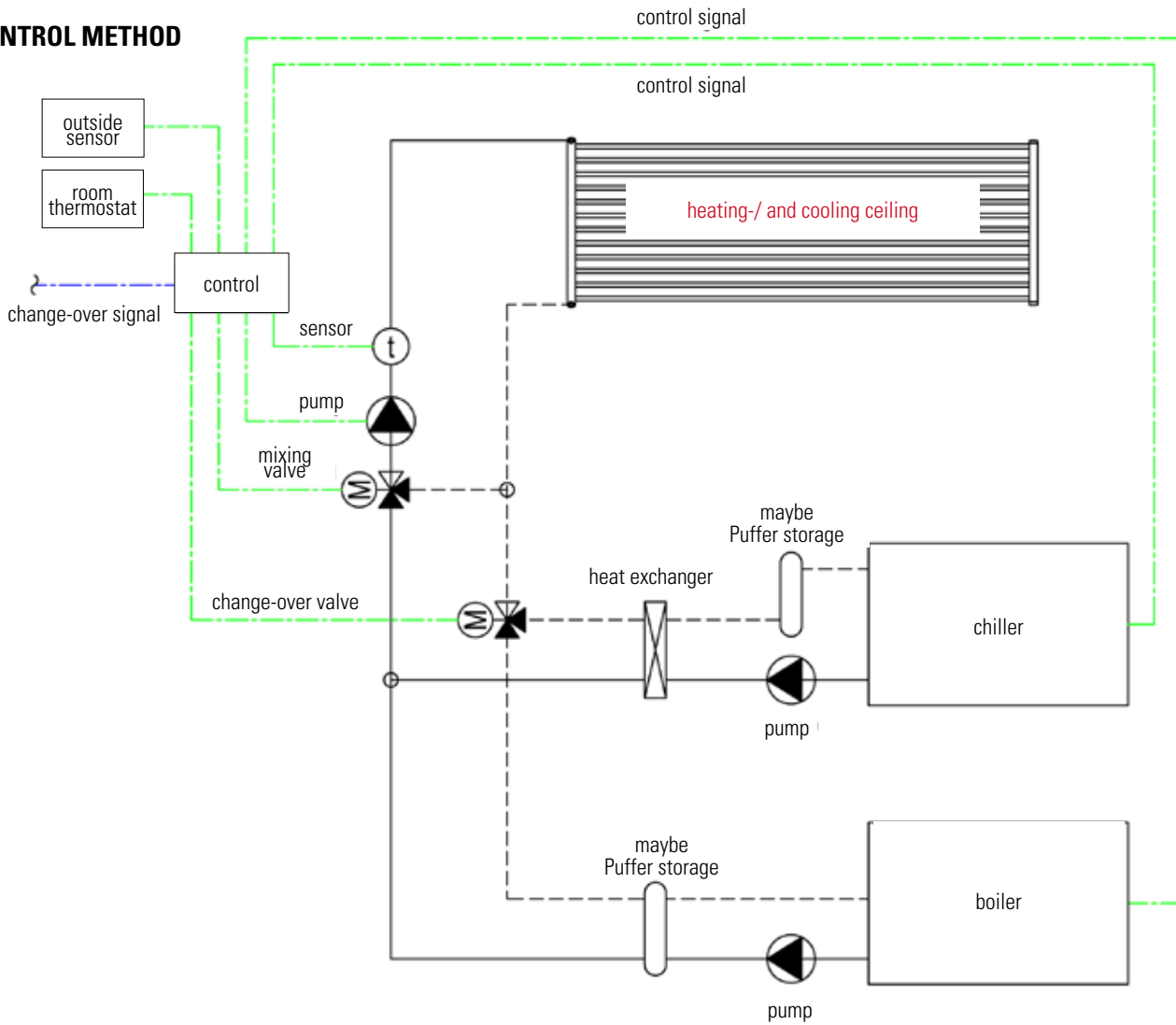

**Control scheme heating/cooling via separate heater/cooler in a two-pipe system**

The control scheme charts the generation of hot and cold water by separate generators in a two-pipe system. If the chiller is placed outdoor it will be required to separate the primary circuit with anti-freezer with a heat exchanger from the secondary circuit. For a better energetic and economic efficiency of the generator a buffer storage, where required, will be used, if it is not still part of the generator. The flow temperature control, controlled by weather conditions, is operated by a programmable control (not subject of the aquatherm product range). The control switching from heating to cooling or reverse is made by the outside sensor or another parameter. It is lead by a control signal to the generator. If it is in operation, the other one will be blocked. The change-over in the pipe system is made by a change-over valve, which is also actuated. At the same time a change-over signal is given, with which the connected room thermostats in the control zones can be switched to heating or cooling.



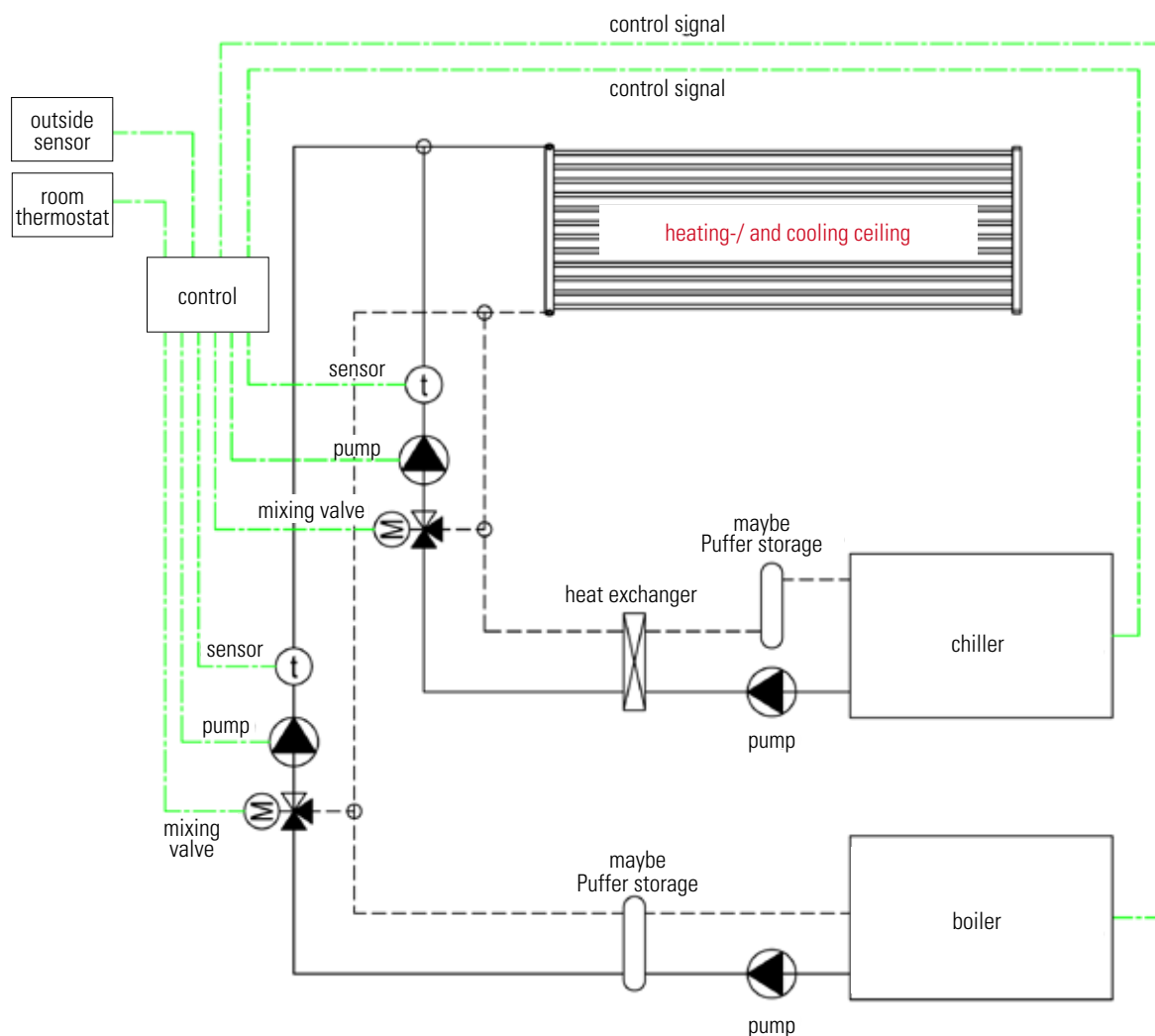

**Control scheme heating/cooling via separate heater/cooler in a four-pipe system**

The control scheme charts the generation of hot and cold water by a separate generator in a four-pipe system. If the chiller is placed outdoor it will be required to separate the primary circuit with anti-freezer with a heat exchanger from the secondary circuit. For a better energetic and economic efficiency of the generator a buffer storage, where required, will be used, if it is not still part of the generator. The flow temperature control, controlled by weather conditions, is operated by a programmable control (not subject of the aquatherm product range). The heating and cooling pipes are lead directly at the control circuit by the four-pipe system. Thus both media are permanently available and can be switched between heating and cooling individually according to the requirements of the room thermostat per control circuit. Such a system offers highest comfort of controlling, as each room can be controlled individually.

## PLANNING AND DESIGN „HEATING AND COOLING“

### Calculation

Generally a heating load calculation acc. to DIN EN 12831 or a cooling load calculation acc. to VDI 2078 has to be performed before designing the aquatherm black system.

$$Q_{\text{Ausl}} = \frac{Q_{\text{H}}}{A_{\text{f}}}$$

$Q_{\text{Ausl}}$  = Dimensioning of heat flux density

$Q_{\text{H}}$  = Thermal output acc. to DIN EN 12831 less the loss of transmission heat by the components covered by wall heating

$A_{\text{f}}$  = Wall surface, covered with wall heating

### Graphs

The following output graphs for the aquatherm wall and ceiling heating in wet and dry construction method have to be taken into consideration.

These graphs are valid for

Wet-construction system with wall plaster with thermal conductivity

$$\lambda = 0,35 \text{ W/mK}$$

as well as plaster covering from upper edge of heating pipe

$$= 10 \text{ mm}$$

aquatherm black system-dry wall heating element (performance diagram valid in connection with gypsum fibre boards)

$$\lambda = 0,32 \text{ W/mK}$$

Dry wall systems (with dry wall board)

$$\lambda = 0,21 \text{ W/mK Dry wall board}$$

$$\lambda = 0,31 \text{ W/mK Thermoboard Comp. Knauf}$$

$$\lambda = 0,45 \text{ W/mK Thermoboard Plus Comp. Knauf}$$

$$\lambda = 0,516 \text{ W/mK climafit Comp. Rigips}$$

Dry wall systems (with metal panel ceiling)

$$\lambda = 46,5 \text{ W/mK Steel plate}$$

$$\lambda = 200 \text{ W/mK Aluminium}$$

### Standards and guidelines

The following standards and guidelines must be considered on planning and design of the aquatherm black system:

VDI 2078 cooling load calculation /

EnEV Energy saving law

DIN EN 1264 Surface heating systems /

DIN 1186 Construction gypsums

DIN 4102 Fire protection in building construction /

DIN 4108 Heat Insulation in building construction /

DIN 4109 Sound Insulation in building construction /

DIN EN 12831 Calculation of the standard heating load /

DIN EN 1264 Hot water under-floor heating /

DIN 4726 Conduits of plastic /

DIN 18164 Foam plastics /

DIN 18165 Fibre insulating materials /

DIN 18180 Gypsum plaster boards /

DIN 18181 Gypsum plaster boards in building construction /

DIN 18182 Accessories for the processing of plaster boards /

DIN 18195 Building sealing /

DIN 18202 Dimension tolerances in building construction /

DIN 18350 Plastering works and stucco works /

DIN 18557 Mortar /

DIN 18550 Plasters

(Individual processing guidelines of the respective manufacturer)

Planning and design

## „HEATING AND COOLING“

### Design of a aquatherm black system-ceiling cooling

For the standard installation situation of the aquatherm black system-ceiling cooling there are standard cooling efficiencies available, according to DIN EN 14240 2004-04.

As the standard cooling efficiency is measured under test conditions, it must be adapted under real conditions. The room conditions (height), the influence of the outside façade with high surface temperatures, the influence of the ventilation on the convective heat transmission of the cooling ceiling and the ventilation of the cooling ceiling by an open shadow gap belong to this.

The influence of these parameters can increase the real cooling efficiency of a aquatherm black system cooling ceiling compared with the standard cooling efficiency by 6 – 10%.

#### Example cooling ceiling

Room:		Office
Room temperature:	$\vartheta_i$	26 °C
Cooling load:	$\Phi_{Ber}$	945 Watt
Ceiling:	$\lambda$	0,31 W/mK (Thermoboard Comp. Knauf)
Standard cooling efficiency ceiling:		63 W/m <sup>2</sup> *
Required grid area:		15,0 m <sup>2</sup>
Flow:	$\vartheta_v$	15 °C
Return:	$\vartheta_r$	17 °C
Linear temperature difference:	$\Delta\vartheta_H$	10 K

$$\Delta\vartheta_H = \vartheta_i - \left( \frac{\vartheta_v + \vartheta_r}{2} \right)$$

#### Design of a aquatherm black system ceiling-and wall heating

Room:		Office
Room temperature:	$\vartheta_i$	20 °C
Cooling load:	$\Phi_{Ber}$	750 Watt
Ceiling:	$\lambda$	0,31 W/mK (Thermoboard Comp. Knauf)
Standard heating efficiency:		50 W/m <sup>2</sup> *
Required grid area:		15,0 m <sup>2</sup>
Flow:	$\vartheta_v$	32 °C
Return:	$\vartheta_r$	27 °C
Linear temperature difference:	$\Delta\vartheta_H$	9,5 K

$$\Delta\vartheta_H = \left( \frac{\vartheta_v + \vartheta_r}{2} \right) - \vartheta_i$$

\* see graph for the standard cooling and heating of the individual systems on pages 28, 32, 34, 39, 43, 48 and 53.

Planning and design

**PRESSURE DROP GRAPH**

aquatherm black system grid

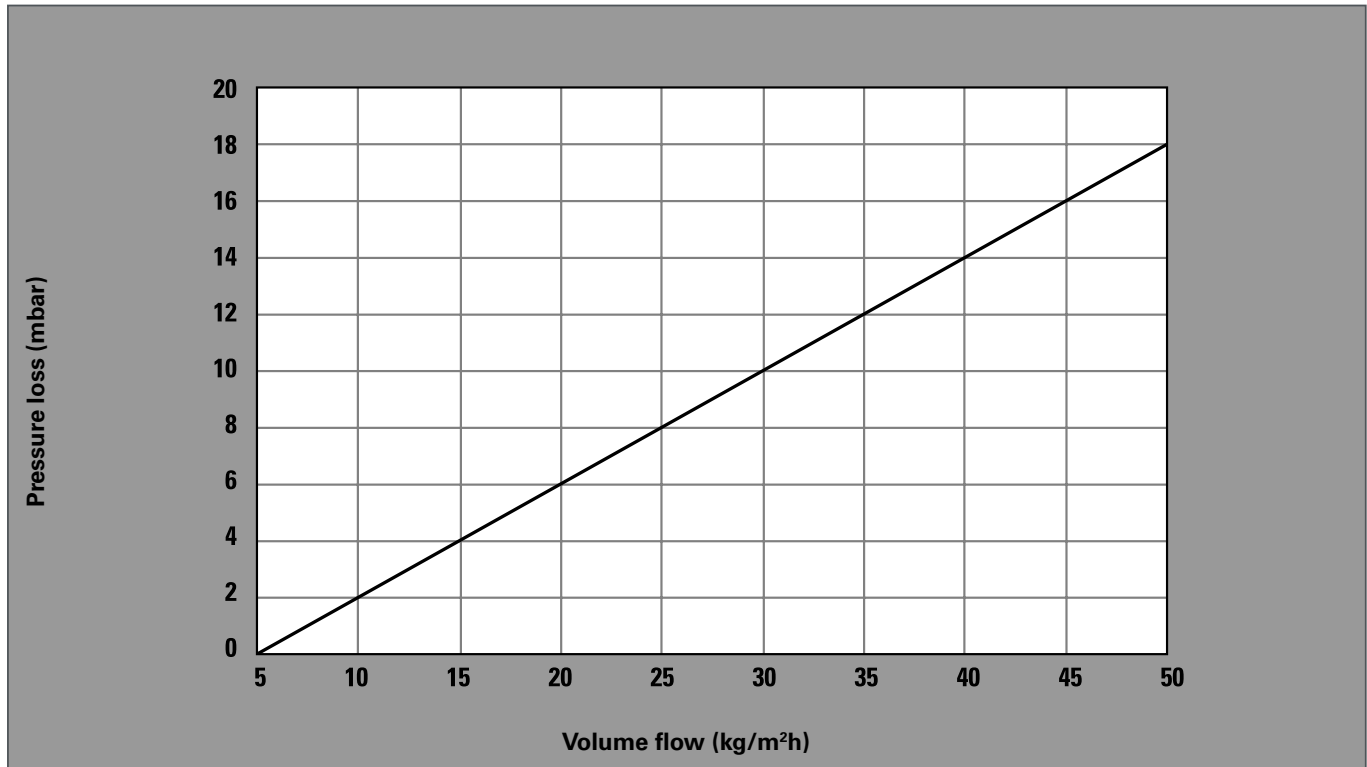

**Determination of pressure loss by graph**

Area occupied with grids:  $A=8,7\text{m}^2$   
 Special cooling efficiency per  $\text{m}^2$ :  $60\text{ W/m}^2$   
 Efficiency of the area:  $522\text{ Watt}$   
 Temperature difference:  $2\text{K}$

Mass flow:

$$\dot{m} = \frac{Q}{c \cdot \Delta v}$$

$$\dot{m} = \frac{522\text{ Watt}}{1,163 \frac{\text{Wh}}{\text{kg} \cdot \text{K}} \cdot 2\text{K}}$$

$$\dot{m} = 224,4\text{ kg/h}$$

Mass flow per  $\text{m}^2/\text{area}$ :  $25,8\text{ kg/m}^2\text{h}$   
 Pressure loss per  $\text{m}^2$ :  $\Delta p=8,3\text{ mbar/m}^2$   
 (is described in graph)  
 Pressure loss area:  $\Delta p = 8,3\text{ mbar/m}^2 \cdot 8,7\text{m}^2$   
 $= 72,2\text{ mbar}$

**Calculation of pressure loss by formula**

Area occupied with grids:  $A=8,7\text{m}^2$   
 Special cooling efficiency per  $\text{m}^2$ :  $60\text{ W/m}^2$   
 Efficiency of the area:  $522\text{ Watt}$   
 Temperature difference:  $2\text{K}$

Mass flow:

$$\dot{m} = \frac{Q}{c \cdot \Delta v}$$

$$\dot{m} = \frac{522\text{ Watt}}{1,163 \frac{\text{Wh}}{\text{kg} \cdot \text{K}} \cdot 2\text{K}}$$

$$\dot{m} = 224,4\text{ kg/h}$$

Pressure loss formula:  $\Delta p = 0,4 \cdot \dot{m} - 2 \cdot A$   
 $= 0,4 \cdot 224,4\text{ kg/h} - 2 \cdot 8,7\text{ m}^2$   
 $= 72,4\text{ mbar}$

Planning and design

### PRESSURE DROP GRAPH

Pressure loss pipe 16x2 mm

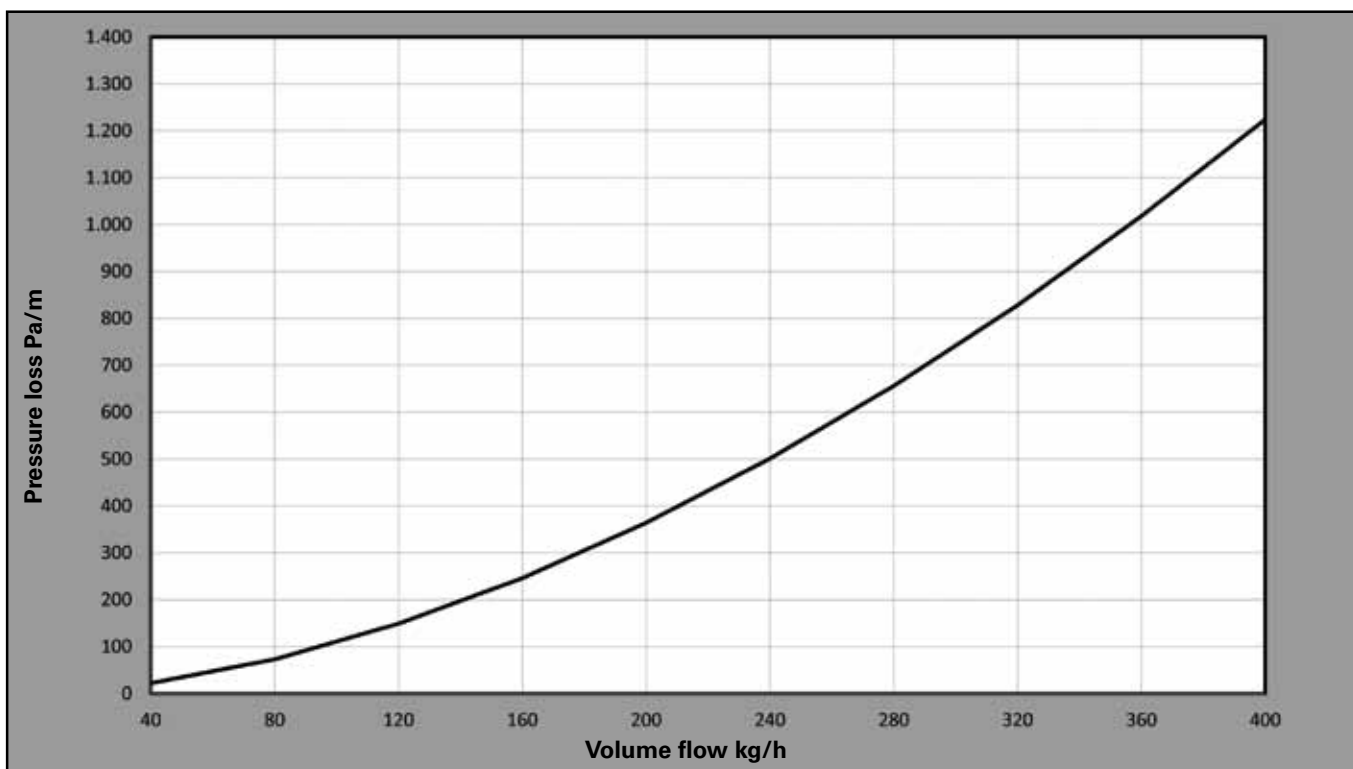

Example: connection supply from the manifold to the area with PP-R grid pipe 16 x 2 mm in coils with a total length of 13,5 m. The volume flow is 240 kg/h. Thus the pressure loss per m is 500 Pa, the total pressure loss for the connection supply is 6.750 Pa.

### Pressure loss of the corrugated connecting pipe

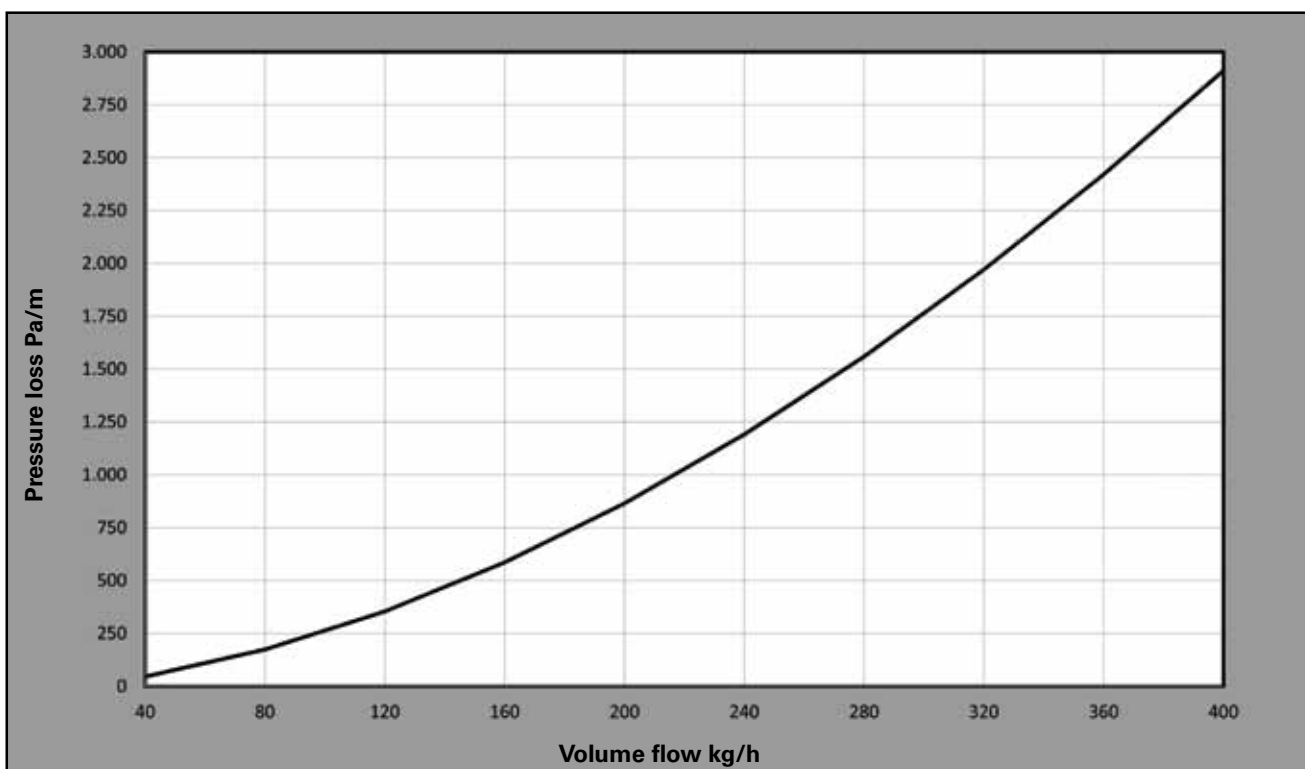

Example: Internal piping of grids with corrugated connecting pipe with a length of 7,5 m. The volume flow is 240 kg/h. Thus the pressure loss per m is 1.190 Pa, the total pressure loss for the internal piping is 8.925 Pa.

## MAXIMUM SURFACE PER EACH COOLING CIRCUIT

Depending on output, volume flow and temperature difference

### aquatherm black system - Temperature difference 3 K)

Output Watt/m <sup>2</sup>	Temp. difference K	Volume flow kg/h	Pressure drop mbar/m <sup>2</sup>	max. surface per cooling circuit in m <sup>2</sup>	
				pipe 16x2 mm	corrugated connecting pipe
30	3	8,60	1,44	15,0	15,0
35	3	10,03	2,01	15,0	15,0
40	3	11,46	2,59	15,0	15,0
45	3	12,90	3,16	15,0	15,0
50	3	14,33	3,73	15,0	15,0
55	3	15,76	4,31	15,0	15,0
60	3	17,20	4,88	15,0	14,5
65	3	18,63	5,45	15,0	13,4
70	3	20,06	6,03	15,0	12,5
75	3	21,50	6,60	15,0	11,6
80	3	22,93	7,17	15,0	10,9
85	3	24,36	7,74	14,8	10,3
90	3	25,80	8,32	14,0	9,7
95	3	27,23	8,89	13,2	9,2
100	3	28,66	9,46	12,6	8,7

### aquatherm black system - Temperature difference 2 K)

Output Watt/m <sup>2</sup>	Temp. difference K	Volume flow kg/h	Pressure drop mbar/m <sup>2</sup>	max. surface per cooling circuit in m <sup>2</sup>	
				pipe 16x2 mm	corrugated connecting pipe
30	2	12,90	3,16	15,0	15,0
35	2	15,05	4,02	15,0	15,0
40	2	17,20	4,88	15,0	14,5
45	2	19,35	5,74	15,0	12,9
50	2	21,50	6,60	15,0	11,6
55	2	23,65	7,46	15,0	10,6
60	2	25,80	8,32	14,0	9,7
65	2	27,94	9,18	12,9	8,9
70	2	30,09	10,04	12,0	8,3
75	2	32,24	10,90	11,2	7,8
80	2	34,39	11,76	10,5	7,3
85	2	36,54	12,62	9,9	6,8
90	2	38,69	13,48	9,3	6,5
95	2	40,84	14,34	8,8	6,1
100	2	42,99	15,20	8,4	5,8

To avoid possible flow noise and too high pressure losses in the circuits, the flow rate in the pipes should not be too high. The optimum value is between 0.75 m/s and 0.85 m/s. That means that in the PP-R grid pipe 16 x2 mm with this flow rate a maximum mass flow rate of 360 kg/h is possible, but with the flexible corrugated pipe it is only maximum 250 kg/h. If now the maximum possible mass flow rate is divided by the mass flow rate per m<sup>2</sup>, it will result in the maximum area per circuit. The area of the cooling circuit, as well as the heating circuit area, is not larger than 15 m<sup>2</sup>.

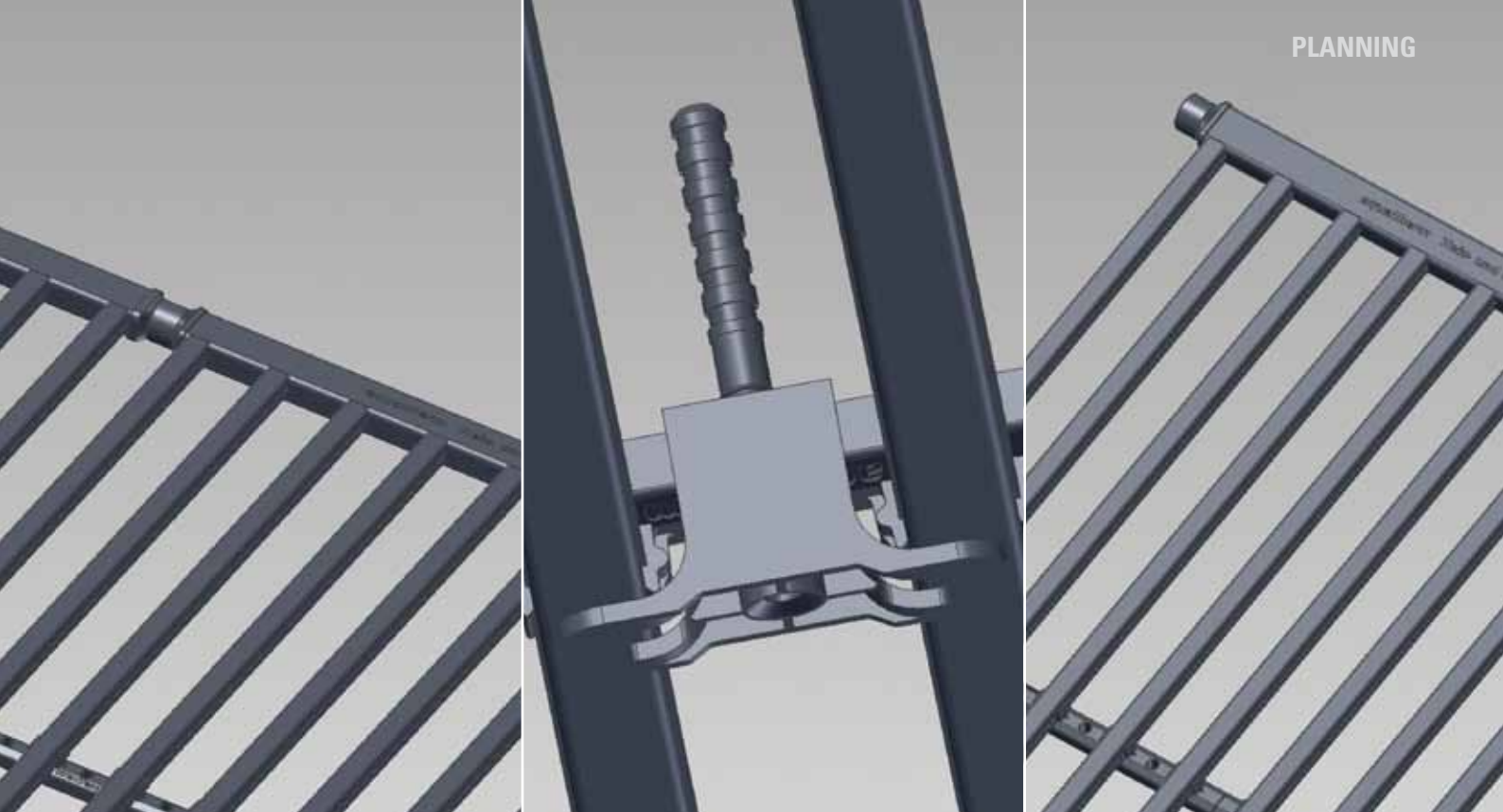

## STARTING

### Flushing, filling and venting

Basically the aquatherm black system has to be pressurized prior to plaster or paneling works. Therefore the pipes must be flushed and filled in zones at the heating circuit manifolds e.g. by filling and drain valves. By the self-bleeding effect of the grids, the air is flushed of the system by correct filling through the pipes. With a low volume flow and low filling pressure (max. 0.5 bar) the water is filled in the system until it leaves bubble-free. Wall heating generally has to be filled from the bottom to the top, i.e. via the return pipe. The hydraulic balancing of the system has to be regulated according to the calculation.

### Leak test

According to the DIN EN 1264-4 the aquatherm black system has to be leak-tested like the underfloor-heating systems. The test pressure must be the double of the operating pressure, but at least 6 bars. To provide for the permanent density the system must be pressurized in intervals.

The system must be charged for one hour with the test pressure. Then the system is unpressurized. Following the system is charged with a pressure of 1 bar for 15 minutes. After again releasing the pressure of the system the process is repeated twice. This test pressure must be kept during the plaster works at the wall or ceiling or during the paneling works.

The density und the test pressure have to be recorded in a test record (is described on page 74).

In danger of freezing suitable measures, like the use of anti-freezer or heating of the building, should be applied. The anti-freezer must be removed by draining and flushing with at least triple water change, if no anti-freezer is required for the normal operation of the system.

### Functional heating

- 1) Functional heating for wet installed surface heating and/or surface heating and cooling systems

The functional heating must be performed for checking the heated respectively cooled wall and ceiling construction. It furnishes proof of an accurate construction. Depending on the thickness and the bonding agent of the heat distributing layer the following minimum drying times must be kept before heating up the system:

Lime cement	1 day per mm layer thickness
Lime:	1 day per mm layer thickness
Gypsum:	½ day per mm layer thickness
respectively:	___ days according to manufacturer's instructions

- 2) Functional heating for surface heating and cooling system as dry system

The functional heating must be performed for checking the function of the heated respectively cooled wall and ceiling construction. The functional heating of dry systems is performed after finishing the filling or bonding works. Filler or bonding must be cured. Manufacturer's instructions must be observed.

Test records for functional heating of wet and dry systems are on page 72 and 73.

**FUNCTIONAL HEATING AS FUNCTIONAL TEST**

Functional test for wet installed surface heating- and/or surface-heating and cooling systems (for wall and ceiling)

Client: \_\_\_\_\_

Building /Property: \_\_\_\_\_

Building section  
Floor/Flat: \_\_\_\_\_

Plant section: \_\_\_\_\_

**Requirements**

The functional heating must be performed for checking the function of the heated respectively cooled wall- or ceiling construction. It furnishes the proof of a construction free from faults. Depending on the thickness and the bonding agent of the heat distributing layer at least the following drying times have to be kept before heating up.

- Lime cement: 1 day per mm layer thickness
- Lime: 1 day per mm layer thickness
- Gypsum: ½ day per mm layer thickness
- respectively. \_\_\_ days acc. to manufacturers' instructions

For 1 day the maximum calculated flow temperature (normally up to 45° C) must be kept. If there is any risk of frost, the system should be kept in operation. Manufacturers' instructions, notwithstanding the record must be observed.

**Documentation**

- 1) Type of heat distribution layer (product, if indicated): \_\_\_\_\_  
bonding agent: \_\_\_\_\_
- 2) End of works at heat distribution layer (date): \_\_\_\_\_
- 3) Start of functional heating (date): \_\_\_\_\_  
with constant max. calculated flow temperature  $t_v = \text{_____}^\circ\text{C}$
- 4) End of functional heating (date): \_\_\_\_\_  
In case of frost risk special precautions should be applied.
- 5) The rooms have been vented without draft and all windows and external doors have been closed after disconnection of the surface heating and cooling system.  
 yes  no
- 6) The system has been released for further construction works at an outside temperature of \_\_\_\_\_°C.  
 In that process the system was out of action.  
 The heat distribution layer was heated with a flow temperature of \_\_\_\_\_°C.

**Note:** When disconnecting the surface heating after the heating-up, the heating surface must be protected from draft and rapid cooling down up to its full cooling.

**Confirmation**

Place/Date	Place/Date	Place/Date
Owner/Client Stamp/Signature	Constructor/Architect Stamp/Signature	Heating engineer Stamp/Signature



**FUNCTIONAL HEATING AS FUNCTIONAL TEST**

Functional test for dry installed surface heating and cooling systems

Client: \_\_\_\_\_

Building/Property: \_\_\_\_\_

Building section  
Floor / Flat: \_\_\_\_\_

Plant section: \_\_\_\_\_

**Requirements**

The functional heating must be performed for checking the function of the heated respectively cooled underfloor, wall- or ceiling construction. In case of dry systems the functional heating is made after finishing of the spattle or bonding works. Surfacers resp. bonding must be cured. Manufacturers' instructions must be observed.

For 1 day the maximum calculated flow temperature (normally up to 45° C) must be kept. If there is any risk of frost, the system should be kept in operation. Manufacturers' instructions, notwithstanding the standard or this record must be observed.

**Documentation**

- 1) Type of heat distribution layer (product, if indicated): \_\_\_\_\_  
bonding agent: \_\_\_\_\_
- 2) End of works at heat distribution layer (date): \_\_\_\_\_
- 3) Start of functional heating (date): \_\_\_\_\_  
with constant max. calculated flow temperature  $t_v = \text{_____}^\circ\text{C}$
- 4) End of functional heating (date): \_\_\_\_\_  
In case of frost risk special precautions should be applied.
- 5) The rooms have been vented without draft and all windows and external doors have been closed after disconnection of the surface heating and cooling system.  
 yes  no
- 6) The system has been released for further construction works at an outside temperature of \_\_\_\_\_°C.  
 In that process the system was out of action.  
 The heat distribution layer was heated with a flow temperature of \_\_\_\_\_°C.

**Note:** When disconnecting the surface heating after the heating-up, the heating surface must be protected from draft and rapid cooling down up to its full cooling.

**Confirmation**

.....  
Place/Date

.....  
Place/Date

.....  
Place/Date

.....  
Owner/Client  
Stamp/Signature

.....  
Constructor/Architect  
Stamp/Signature

.....  
Heating engineer  
Stamp/Signature

**LEAK TEST OF SURFACE HEATINGS AND SURFACE COOLINGS**

Test record

Client: \_\_\_\_\_

Building/Property: \_\_\_\_\_

Building section  
Floor / Flat: \_\_\_\_\_

**Requirements**

The leak-tightness of the heating/cooling circuits of the surface heating/surface cooling is assured by a water pressure test right before laying the screed, plaster resp. levelling compound.

The test pressure must be – differing from the VOB – the double of the operating pressure, but at least 6 bars. This pressure must be kept during the filling with screed/plaster.

**Maximum allowable operating pressure 4 resp. 6 bar**

**Principle test**

- 1. Operation pressure            6 bar  
     Pressure after 60 Min.            \_\_\_\_\_ bar
- 2. Operation pressure            1 bar  
     Pressure after 15 Min.            \_\_\_\_\_ bar

**Interval test**

- 1. Operating pressure 6 bar \_\_\_\_\_ bar  
     minimum 60 min, then  
     Operating pressure 1 bar \_\_\_\_\_ bar  
     minimum 15 min
- 2. Operating test 6 bar \_\_\_\_\_ bar  
     minimum 60 min, then  
     Operating pressure 1 bar \_\_\_\_\_ bar  
     minimum 15 min

**\* Between each cycle the pipe must be unpressurized**

The density has been established; no permanent deformations occurred at any structural element.

**Confirmation**

Place/Date	Place/Date	Place/Date
Owner/Client Stamp/Signature	Constructor/Architect Stamp/Signature	Heating engineer Stamp/Signature

# aquatherm black system

## HEATING AND COOLING GRIDS

Connection types of the grids	Width of grids	Length of grids
50 = DD Welding connection AX	24 cm	40 cm
64 = DD Welding connection LR with flow break	28 cm	50 cm
65 = DD Welding connection LR with flow break	32 cm	60 cm
51 = 45° Plug connection TL/LR	36 cm	70 cm
58 = 45° Welding connection TL / Plug connection LR	40 cm	80 cm
59 = 45° Welding connection TL /LR	48 cm	90 cm
52 = 90° Plug connection TL/LR	56 cm	100 cm
53 = 90° Plug connection TR/LL	60 cm	120 cm
62 = 90° Plug connection LR with flow break	68 cm	140 cm
	80 cm	160 cm
	100 cm	180 cm
56 = Weldable connecting elbow TL/LR*		200 cm
(please note: Connection type 56 only available as dry wall heating element)		225 cm
		250 cm
		275 cm
		300 cm
		325 cm
		350 cm
		375 cm
		400 cm
		425 cm
		450 cm
		475 cm
		500 cm

L=lower, T=top, L=left, R=right, AX=axial

Special sizes on request

### Composition of the Article-numbers:

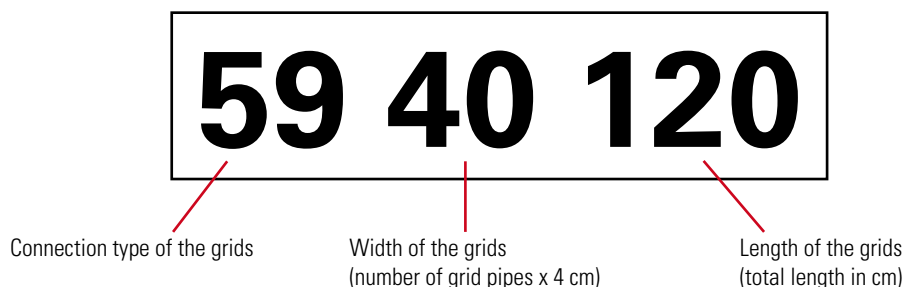

\* Please consider the differing composition of the article number of the connection type 56 on page 14.

**aquatherm black system - DRY WALL HEATING ELEMENT**

oxygen-tight, with pipe nozzle, male end for welded connection

Art.-No.	Dimension	PU
<b>5662050</b>	62,5 x 50 cm	2
<b>5662100</b>	62,5 x 100 cm	2
<b>5662200</b>	62,5 x 200 cm	2

Connection: PP-R 16 mm, weldable

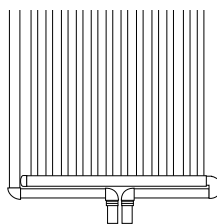

**aquatherm black system - CORRUGATED CONNECTING PIPE**

oxygen-tight, weldable, for Art.-No. 5662050-5662200

Art.-No.	Dimension	PU
<b>81044</b>	59,5 cm	1

with twosided 90° elbow



**aquatherm black system - DRY WALL HEATING ELEMENT**

with oxygen barrier, with SHT connection

Art.-No.	Dimension	PU
<b>5663050</b>	62,5 x 50 cm	2
<b>5663100</b>	62,5 x 100 cm	2
<b>5663200</b>	62,5 x 200 cm	2

Connection: SHT-sliding sleeve technology

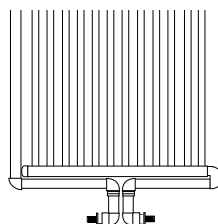

**aquatherm black system - JOINT ADHESIVE**

for aquatherm black system - dry wall heating element

Art.-No.	Dimension	PU
<b>81003</b>	for 310 mm cartridge	1

The Fermacell-joint adhesive and further Fermacell products (drywall screws etc.) may be purchased directly at the wholesale.



**aquatherm grey pipe - ADAPTER**

to aquatherm green and blue pipe systems, including sliding sleeve - for aquatherm grey pipe Art.-No. 777050 ... 777072

Art.-No.	Dimension	PU
<b>78320</b>	aquatherm green pipe 16 mm x aquatherm grey pipe 16 mm	1

Material: PP-R/Brass



**LEGEND**  
**PU** = Packing unit

**aquatherm black system - PP-GRID CONNECTING PIPE**

with oxygen barrier, in 2,5m straight lengths

Art.-No.	Dimension	PU
<b>81006</b>	16 mm	50
<b>81008</b>	20 mm	50

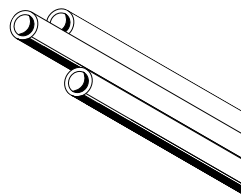

**aquatherm black system - PP-GRID CONNECTING PIPE**

with oxygen barrier, in coils

Art.-No.	Dimension	PU
<b>81026</b>	16 mm	100
<b>81028</b>	20 mm	100

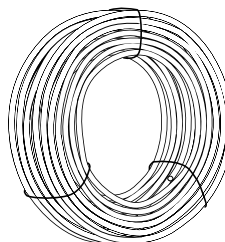

**aquatherm black system - PLASTIC PIPE CLAMPS**

suitable for ø 16 mm pipes

Art.- Nr.	For pipe dimension	PU
<b>60716</b>	16 mm	50

Colour: anthracite

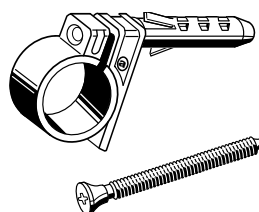

**aquatherm black system - SOCKET**

for heating and cooling grids

Art.-No.	Dimension	PU
<b>81050</b>	16 mm	10

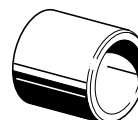

**aquatherm black system - ELBOW 90°**

for heating and cooling grids

Art.-No.	Dimension	PU
<b>81060</b>	16 mm	10



**aquatherm black system - ELBOW 90°**

female/male

Art.-No.	Dimension	PU
<b>81065</b>	16 mm	10



**aquatherm black system- END CAP**

for heating and cooling grids

Art.-No.	Dimension	PU
<b>81080</b>	16 mm	10



**aquatherm black system - PP-R MALE END PLUG**

for heating and cooling grids - connection type 50

Art.-No.	Dimension	PU
<b>81092</b>	16 mm	50

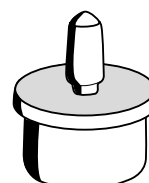

**aquatherm black system - FIXING RAIL FOR WALL HEATING**

for heating and cooling grids

Art.-No.	Dimension	PU
<b>81506</b>	Length = 24 cm	10



**aquatherm black system - DOUBLE SOCKET**

calibrated pipe nipple for connection of plug adapter

Art.-No.	Dimension	PU
<b>81093</b>	16 x 2 mm, Length: 150 mm	



**aquatherm black system - WALL BRACKET**

for heating and cooling grids

Art.-No.	Dimension	PU
<b>81296</b>	-	10



**aquatherm black system - FIXING RAIL FOR DRY WALL**

for heating and cooling grids

Art.-No.	Dimension	PU
<b>81297</b>	-	10

Please note, when ordering the fixing rail for drywall art.-no. 81297, that for each rail two cable ties with the art.-no. 99086 have to be ordered.



**CABLE TIE**

Art.-No.	Dimension	PU
<b>99086</b>	Length: 200 mm	100

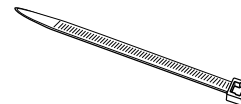

**aquatherm black system - FIXING CLAMP WITH WALL PLUG**

for wall and ceiling installation

Art.-No.	Dimension	PU
<b>81298</b>	-	10



**aquatherm black system - HEATING AND COOLING GRID FOR CEILING PANELS**

with oxygen barrier, with plug connection on side

Art.-No.	Dimension	PU
<b>5160061</b>	for ceiling panels 62,5 x 62,5 cm	10
<b>5156058</b>	for ceiling panels 60 x 60 cm	10



Special dimensions on request

**aquatherm black system - CORRUGATED CONNECTING PIPE**

in coils, with oxygen barrier

Art.-No.	Dimension	PU
<b>81039</b>		50



Connectable by welding with Art. 81288, 81289, 81290, 81291 separable every 25 cm

**aquatherm black system - CORRUGATED CONNECTING PIPE**

with oxygen barrier, for Art.-No. 5161061 and 5157058

Art.-No.	Dimension	PU	PG
<b>81040</b>	Length = 57 cm, double-sided pushfit connection	10	20
<b>81041</b>	Length = 57 cm, one-sided pushfit connection/ one-sided SHT 16 mm	10	20
<b>81042</b>	Length = 57 cm, one-sided pushfit connection/one-sided SHT 16 mm, weldable	10	20

with safety pin

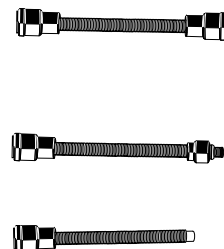

**aquatherm black system - HEATING AND COOLING GRID FOR CEILING PANELS**

retractable, oxygen tight, with one-side 90° plug connection and flow break

Art.-No.	Dimension	PU	PG
<b>6256060</b>	for ceiling panels 62,5 x 62,5 push-fit connection	1	20
<b>6256056</b>	for ceiling panels 60,0 x 60,0 weldable	1	20
<b>6252056</b>	for ceiling panels 60,0 x 60,0 push-fit connection	1	20
<b>6256120</b>	for ceiling panels 62,5 x 125,0 push-fit connection	1	20

Forced flow by in-centre welded blind plug in the main pipe, which offers a one-side connection of the grids among each other.

Special sizes on request.

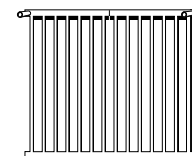

**aquatherm black system - CORRUGATED CONNECTING PIPE**

with oxygen barrier, for connection types 52, 53 and 62

Art.-No.	Dimension	PU	PG
<b>81030</b>	L 1,25m with elbow double sided push-fit connection	1	20
<b>81031</b>	L 0,5m with elbow push-fit connection/weldable	1	20
<b>81032</b>	L 0,5m with elbow double sided push-fit connection	1	20
<b>81035</b>	L 1,5m with elbow double sided push-fit connection	1	20
<b>81036</b>	L 1,75m with elbow double sided push-fit connection	1	20

with safety pin

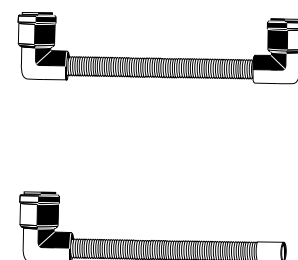

**aquatherm black system - THERMOGRAPHIC FILM**

place at the wall for indicating the position of the pipe by colour changing

Art.-No.	Dimension	PU	PG
<b>50186</b>	160 x 70 mm	1	20



**aquatherm black system - ADAPTER**

one-sided pluggable / one-sided PP-R 16 mm weldable

Art.-No.	Dimension	PU	PG
<b>81288</b>	16 mm	20	20

with safety pin

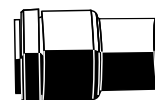

**aquatherm black system - T-ADAPTER**

Passage PP-R 25 mm weldable / branch 16 mm pluggable

Art.-No.	Dimension	PU	PG
<b>81289</b>	25 x 16 x 25 mm	10	20

with safety pin

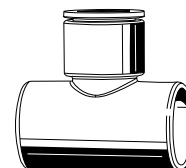

**aquatherm black system - 90° ELBOW-ADAPTER**

one-sided pluggable / one-sided PP-R 16 mm weldable

Art.-No.	Dimension	PU	PG
<b>81290</b>	16 mm	10	20

with safety pin

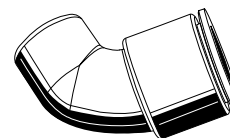

**aquatherm black system - 45° ELBOW-ADAPTER**

one-sided pluggable / one-sided PP-R 16 mm weldable

Art.-No.	Dimension	PU	PG
<b>81291</b>	16 mm	1	20

with safety pin

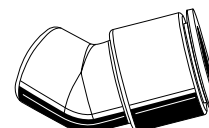

**aquatherm black system - SEALING PLUG**

for wall and ceiling grids

Art.-No.	Dimension	PU	PG
<b>81091</b>	12 mm	10	20

Welding tool for sealing plug Art.-No. 50285



**aquatherm black system - WELDING TOOL**

Art.-No.	Dimension	PU	PG
<b>50285</b>		1	3

for sealing plug Art.-No. 81091

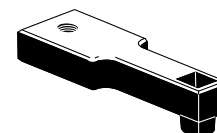



**aqualtherm orange system - HEATING CIRCUIT MANIFOLD WITH FLOW METER**

screw joints and ball valves have to be ordered separately

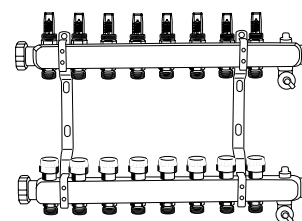

Art.-No.	Dimension	PU
92302	2 Circuits	1
92303	3 Circuits	1
92304	4 Circuits	1
92305	5 Circuits	1
92306	6 Circuits	1
92307	7 Circuits	1
92308	8 Circuits	1
92309	9 Circuits	1
92310	10 Circuits	1
92311	11 Circuits	1
92312	12 Circuits	1

Stainless steel manifold with the following properties:

- flow- and return manifold are arranged separately
- flow indicator with shut-off in the flow
- control and shut-off valve with protection cap in return
- feed and drain valves
- air valves
- bracket set with bow and sound protection
- sealing plug

**aqualtherm orange system - EUROCONUS CONNECTOR**

for heating circuit manifold, valves/couplings

Art.-No.	Dimension	PU
92100	for pipes $\varnothing$ 10 x 1,25 mm	5
92104	for pipes $\varnothing$ 14 x 2,0 mm	5
92106	for pipes $\varnothing$ 16 x 2,0 mm	5
92107	for pipes $\varnothing$ 17 x 2,0 mm	5
92108	for pipes $\varnothing$ 20 x 2,0 mm	5

Union nut nickel-plated

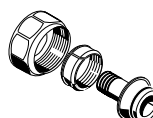

**aqualtherm orange system - BALL VALVE SET**

Straight design, for manifold Art.-No. 92302-92312

Art.-No.	Dimension	PU
92320		

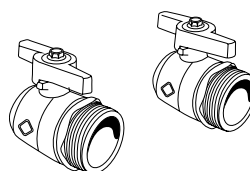

**aqualtherm orange system - BALL VALVE SET**

Corner design, for manifold Art.-No. 92302-92312

Art.-No.	Dimension	PU
92321		

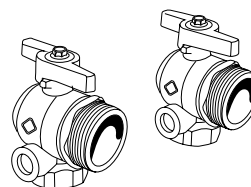

**aqualtherm orange system - LINE CONTROL VALVE SET FOR MANIFOLD**

Art.-No.	Dimension	PU
92329	1"	1

For restriction of flow rate respectively for hydraulic balancing of manifolds

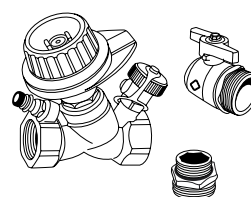

**aquatherm orange system - UNIVERSAL-FLOW METER**

add-on kit with elbow

Art.-No.	Dimension	PU
<b>92323</b>	1"	

for mounting to aquatherm orange system-manifold

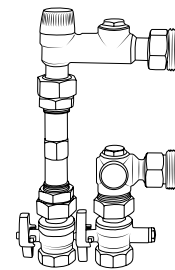

**aquatherm orange system - HEATING CIRCUIT MANIFOLD EXTENSION SET**

für Art.-Nr. 92302-92312

Art.-No.	Dimension	PU
<b>92069</b>		

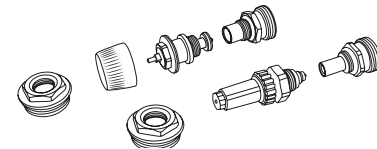

**aquatherm orange system - ACTUATOR**

for heating circuit manifolds and heating circuit control valves - flow

Art.-No.	Dimension	PU
<b>94102</b>	230 volt	1
<b>94103</b>	24 volt	1

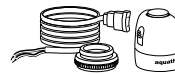

**aquatherm orange system - INDIVIDUAL ROOM CONTROL**

with RTL valve and axial Th valve

Art.-No.	Dimension	PU
<b>94161</b>	-	1

- for control of
- return temperature
  - room temperature
  - in connection for euroconus
  - with concealed manifold cabinet
  - with covering



**aquatherm orange system - AB-QM COMBINATION VALVE**

for hydraulic balancing and control in cooling and heating systems

Art.-No.	Dimension	PU
<b>94165</b>	DN 15 - 3/4"	1



## CONNECTION SYSTEMS, THERMOSTATS 230 VOLT (HEATING)

### aquatherm orange system - CONNECTION SYSTEM AB 2000-6

230 volt

Art.-No.	Dimension	PU
<b>94140</b>		1

Up to 6 room thermostats connectable  
max. 14 actuators  
(extension: see modules)

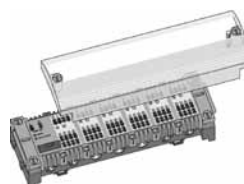

### aquatherm orange system - CONTROL MODULE AB RM 20000

230 volt

Art.-No.	Dimension	PU
<b>94141</b>		1

for extension of 2 room thermostats  
up to 2 room thermostats connectable  
8 actuators

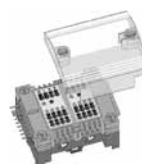

### aquatherm orange system - ACTUATOR MODULE AB AM 2000

230 volt

Art.-No.	Dimension	PU
<b>94142</b>		1

for extension of actuators for large heating surfaces  
up to 2 groups with each 4 actuators are connectable

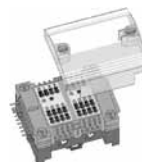

### aquatherm orange system - TIMER MODULE AB TM 1000

230 volt, 24 volt and for radio connection system

Art.-No.	Dimension	PU
<b>94143</b>		1

pluggable 2 channel-digital clock for simple and comfortable programming of the heating times  
Function: 2 week programmes / 42 storage locations  
automatic switching between sommer-/wintertime

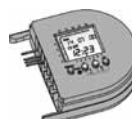

### aquatherm orange system - PUMP MODULE AB PL 2000

230 Volt

Art.-No.	Dimension	PU
<b>94144</b>		1

pluggable extension for controlling of circulation pump  
Connection options: 2 x NYM 2 x 1,5 mm<sup>2</sup> for external pump

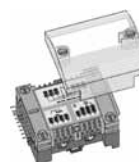

**CONNECTION SYSTEMS, THERMOSTATS 230 VOLT (HEATING)**

**aquatherm orange system - ROOM THERMOSTAT**

230 volt - 50 Hz - differential gap 0,5 K, prepared for night setback

Art.-No.	Dimension	PU
<b>94107</b>	white	1

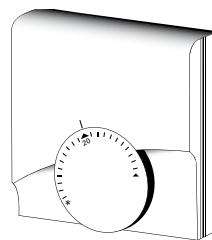

**aquatherm orange system - PROGRAMMABLE ROOM THERMOSTAT, ANALOGUE**

230 volt digital timer with day and week program

Art.-No.	Dimension	PU
<b>94108</b>	white	1

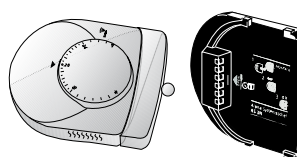

**CONNECTION SYSTEMS, THERMOSTATS 24 VOLT - RADIO CONTROLLED (HEATING)**

**aquatherm orange system - AUTOMATIC CONTROL, WIRELESS AB 4071-6**

24 volt

Art.-No.	Dimension	PU
<b>94148</b>		1

up to 6 radio controls (wireless) connectable  
13 actuators (24 volt)  
transformer: 230V/24V, 50/60 Hz, 50 vA  
operating voltage: 24V/50/60 Hz

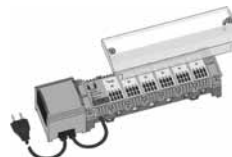

**aquatherm orange system - AUTOMATIC CONTROL, WIRELESS AB 4071-12**

24 volt

Art.-No.	Dimension	PU
<b>94149</b>		1

up to 12 radio controls (wireless) connectable  
13 actuators (24 volt)

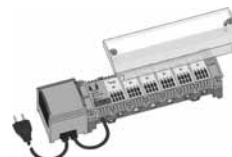

**aquatherm orange system - ROOM THERMOSTAT WIRELESS AR 4070 KF**

Art.-No.	Dimension	PU
<b>94151</b>		1

Room thermostats with wireless radio transmission (battery 2 x 1,5 V Mignon)  
temperature range: 10 - 28 °C

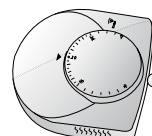

## CONNECTION SYSTEMS, THERMOSTATS 24 VOLT (HEATING/HEATING AND COOLING)

### aquatherm orange system - CONNECTION SYSTEM AB 4001-6

24 volt

Art.-No.	Dimension	PU
<b>94152</b>		1

Connections: up to 6 room thermostats 24 v respectively room thermostats Art.-No. 94156/94154  
14 actuators (24volt)  
Transformer: 230V/24V, 50/60 Hz, 50 vA  
Operating voltage: 24V/50/60 Hz

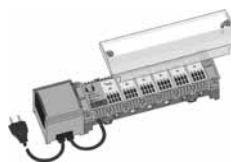

### aquatherm orange system - CONTROL MODULE AB RM 4000

24 volt

Art.-No.	Dimension	PU
<b>94131</b>		1

for extension of 2 room thermostats  
up to 2 room thermostats connectable  
8 actuators

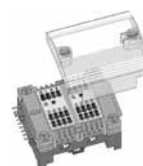

### aquatherm orange system - ACTUATOR MODULE AB AM 4000

24 volt

Art.-No.	Dimension	PU
<b>94132</b>		1

for extension of actuators of large heating surfaces  
up to 2 groups with each 4 actuators connectable

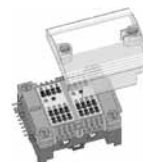

### aquatherm orange system - PUMP MODULE AB PL 4000

24 volt and for radio

Art.-No.	Dimension	PU
<b>94150</b>		1

pluggable extension for controlling of circulation pump  
Connection options: 2 x NYM 2 x 1,5 mm<sup>2</sup> for external pump

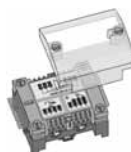

### aquatherm orange system - ROOM THERMOSTAT

24 volt differential gap 0,5 K, prepared for night set-back

Art.-No.	Dimension	PU
<b>94156</b>	white	1

Including mounting base and electrical connection for room thermostats  
- suitable for wall installation and mounting on switch box

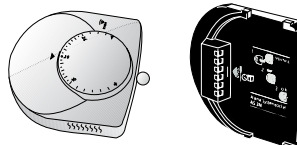

**CONNECTION SYSTEMS, THERMOSTATS 24 VOLT (HEATING/HEATING AND COOLING)**

**aquatherm orange system - HEATING / COOLING MODULE AB HK 4000**

24 volt

Art.-No.	Dimension	PU
<b>94153</b>		<b>1</b>

The plug-in extension of the connection system automatically initiates the change-over of all connected room thermostats into cooling mode by external potential-free contact or manually.



**aquatherm orange system - ROOM THERMOSTAT FOR HEATING AND COOLING AR 4010 K**

24 volt

Art.-No.	Dimension	PU
<b>94154</b>		<b>1</b>

Room thermostat for heating and cooling in one system  
 Temperature range: 10 - 28 °C  
 Operating voltage: 24V, 50/60 Hz  
 Including mounting base and electrical connection for room thermostats  
 - suitable for wall installation and mounting on switch box

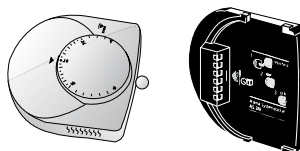

**aquatherm orange system - ADAPTER PLUG FOR EXTERNAL LOWERING**

24 volt

Art.-No.	Dimension	PU
<b>99408</b>		<b>1</b>

Plug-in extension of the connecting system effects the automatic switching (Art.-No. 94034) of all connected room thermostats into the cooling mode by external potential-free contact or manually.

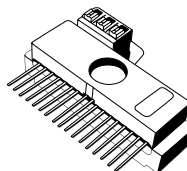

**aquatherm orange system - ROOM THERMOSTAT FOR HEATING AND COOLING**

24 volt

Art.-No.	Dimension	PU
<b>94034</b>		<b>1</b>

Room thermostat with in-wall case for switch boxes acc. to DIN 49073  
 connectable with dewpoint sensor  
 Temperature range: 5 - 30 °C  
 Operating voltage: 24V, 50/60 Hz

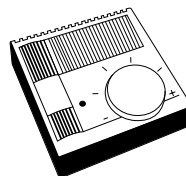

**aquatherm orange system - DEWPOINT CONVERTER**

24 volt

Art.-No.	Dimension	PU
<b>94035</b>		<b>1</b>

Dewpoint converter for switching off the cooling unit or for closing the mixer / valve via potential-free relay contact

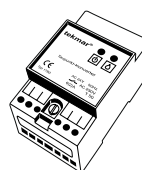

**aquatherm orange system - DEWPOINT SENSOR**

24 volt

Art.-No.	Dimension	PU
<b>94036</b>		1

Humidistat with flexible foil  
 Length of supply = 10 m  
 (LIYY 2 x 0.15 mm)

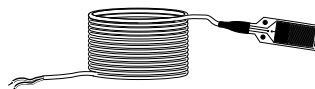

**CONNECTION SYSTEMS, THERMOSTATS 230 VOLT (HEATING AND COOLING)**

**aquatherm orange system - CONTROL MANIFOLD ASV 6**

230 volt

Art.-No.	Dimension	PU
<b>94170</b>		1

up to 6 room thermostats connectable  
 max. 12 actuators



**aquatherm orange system - ROOM THERMOSTAT NRT 210**

230 volt, differential gap 0,5 K, for 2 pipe-systems

Art.-No.	Dimension	PU
<b>94172</b>	white	1

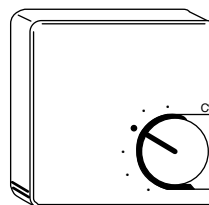

**aquatherm orange system - ROOM THERMOSTAT NRT 220**

230 volt, differential gap 0,5 K, for 4 pipe-systems

Art.-No.	Dimension	PU
<b>94174</b>	white	1

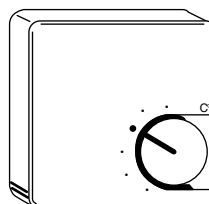

EXAMPLES

SHB, MUNICH, GERMANY

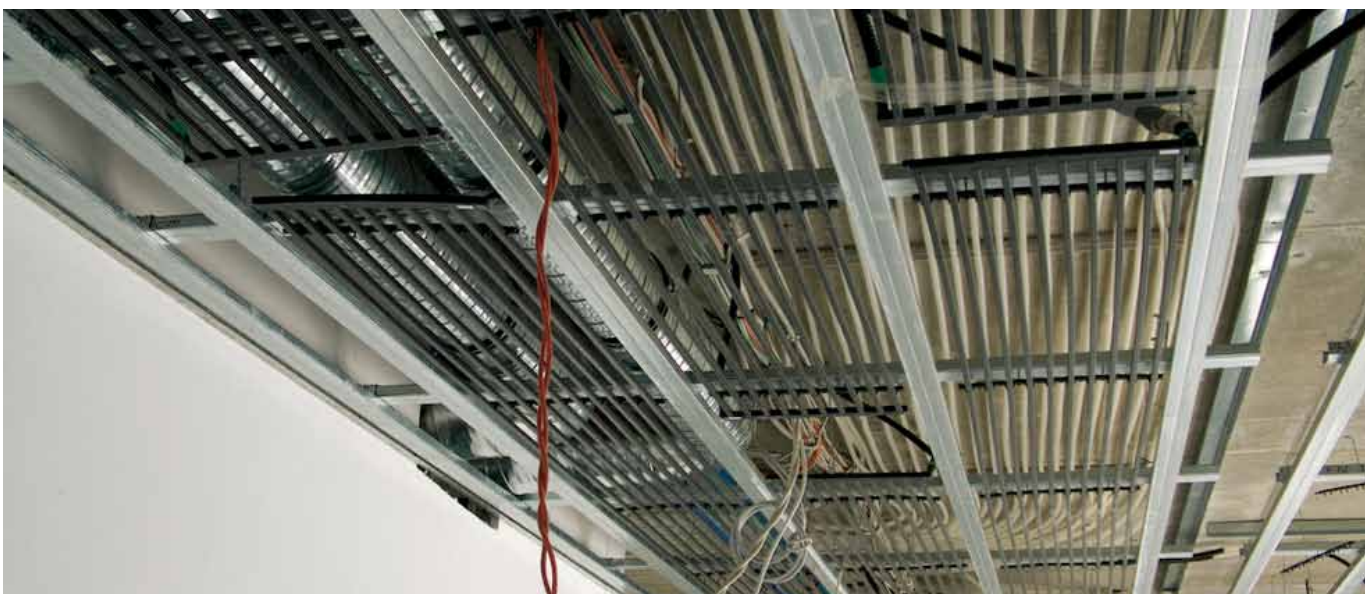



EXAMPLES

MENNEKES, LENNESTADT, GERMANY



EXAMPLES

HANSE HOTEL, ATTENDORN, GERMANY



EXAMPLES

AXA, ANTWERPEN, BELGIUM

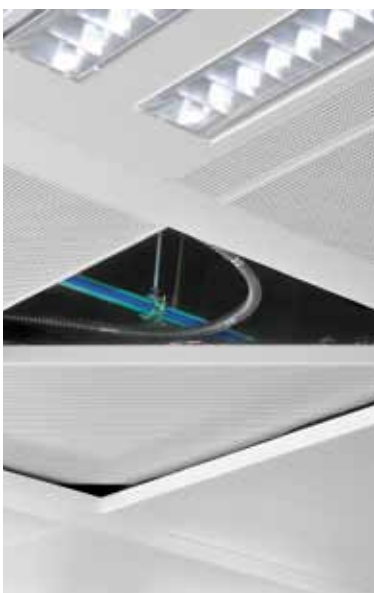

EXAMPLES

SKY OFFICE, ZAGREB, CROATIA







## **GENERAL CONDITIONS**

---

**Our General Conditions of Sale and Delivery (Date: 2014) are printed completely on our homepage [www.aquatherm.de](http://www.aquatherm.de) or we will send them to you on demand!**

Subject to technical alterations, errors and misprints excepted. With the edition of this catalogue, all former ones become void.

---



Management  
System  
ISO 9001:2008  
ISO 14001:2004  
ISO 50001:2011  
[www.tuv.com](http://www.tuv.com)  
ID 0091005348

## aquatherm GmbH

Biggen 5 | D-57439 Attendorn | Phone: +49 (0) 2722 950-0 | Fax: +49 (0) 2722 950-100

Wilhelm-Rönsch-Str. 4 | D-01454 Radeberg | Phone: +49 (0) 3528 4362-0 | Fax: +49 (0) 3528 4362-30

[info@aquatherm.de](mailto:info@aquatherm.de) [www.aquatherm.de](http://www.aquatherm.de)