

# Belriv®

de *Nicoll*

## FASCIA AND SOFFIT SYSTEMS



**BUILDING**  
SANITARY  
ENVIRONMENT

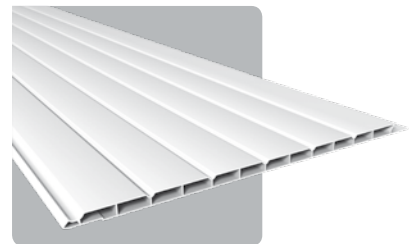

**BUILDING - SANITARY - ENVIRONMENT**







# BELRIV® Fascia and soffits

A perfect finish for new and renovated buildings.

**Belriv®** fascia and soffit systems for eaves are rigid, strong, discreet and elegant to be perfectly in keeping with all types of architecture, both new and renovated.

## TYPE OF CLADDING

## YOUR PROJECT

	FASCIA PROFILE	TYPE OF FASCIA AND SOFFIT (thickness in mm)	CHARACTERISTICS	FITTING	HEIGHTS	COLOURS	BUDGET
<b>Belriv® Tradi</b>		Belriv® Tradi 7 mm	- Fitted to wood fascia. - Back embossed to ventilate wood fascia. - "Teardrop" profile.	Nailed	10 cm, 15 cm 17.5 cm, 20 cm 22.5 cm, 25 cm 30 cm and 40 cm (double facing).	White Sand Cork	€
		Belriv® Tradi 15 mm	- Fitted to rafter or truss. - High density for extreme rigidity. - "Teardrop" profile.	Nailed	15 cm, 17.5 cm, 20 cm, 22.5 cm, 25 cm and 40 cm (double facing).	White Sand	€ €
		Belriv® Tradi 18 mm	- Fitted to rafter or truss. - Overlapping rounded profile.	Nailed	15 cm, 17.5 cm, 20 cm, 22.5 cm, 25 cm and 40 cm (double facing).	White Sand	€ € €
<b>Belriv® Système</b>		Belriv® Système 25 mm	- Load-bearing fascia for gutter system. - Technically evaluated for bearing the last row of tiles (avoids the need for a supporting batten).	1/4 turn plate allowing for expansion. Invisible fastening.	17 cm 21 cm With 8 cm extension: 25 cm 29 cm	Grey White Sand Brown Black	€ €
<b>Hollow soffit</b>		Traditional soffit 8 mm	- Traditional wood panel design (6 panels).	Clipped (can be nailed or stapled using the perforated cleat).	400 x 8 x 287	Grey White Sand Brown Black	€
		Modern soffit 8 mm	- Modern broad panel design (3 panels).	Clipped (can be nailed or stapled using the perforated cleat).	400 x 8 x 332	White Sand Cork	€

## Durability guaranteed 10 years



Pollution and corrosion resistant



Freeze resistant

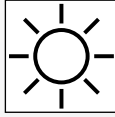

UV resistant

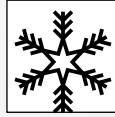

Shock resistant



Maintenance free

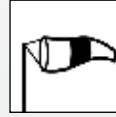

Strong wind resistant



For all these reasons, Nicoll offers a 10 years contractual guarantee for Belriv® System and gutters system.



The materials and finishes of Belriv® systems require no maintenance, paint or protective coating.

## YOUR TYPE OF CONSTRUCTION



TIMBERS		NEW					RENOVATION			
ALIGNMENT DEFECTS		RAFTER OR TRUSS	WOOD COUNTER-FASCIA	DISTANCE BETWEEN TRUSSES > 0.60 CM	FASCIA BEARING 1 <sup>ST</sup> ROW OF TILES	NO EAVES	WOOD COUNTER-FASCIA IN GOOD CONDITION	FASCIA BEARING 1 <sup>ST</sup> ROW OF TILES	REPLACEMENT OF DAMAGED WOOD FASCIA OR RAFTER CLADDING WITH NO WOOD FASCIA	PAGES
MINOR	MAJOR									
	Use compensating wedge									pages 4 - 7
	Use compensating wedge									pages 4 - 7
	Use compensating wedge									pages 4 - 7
										pages 8 - 11
										pages 12 - 15
										pages 12 - 15



# BELRIV<sup>®</sup> SYSTEM Cladding for eaves

How to make roofs handsome.

**Belriv<sup>®</sup> System** is the perfect solution for cladding eaves down to the last detail. Combined with **Nicoll** guttering, it is unbeatable for finishing a roof in style.

## ADVANTAGES

- Patented 1/4 turn plate system allowing for expansion.
- No maintenance.
- Frost and UV resistant.
- 100% recyclable.
- 10-year warranty.
- 5 colours: white, sand, black, brown and grey.
- Load-bearing fascia to support guttering with clip fastening.
- Technically evaluated for bearing the last row of tiles (avoids the need for a supporting batten).



ATEC N° 14 + 5/04-923\*01 Add



## OVERVIEW OF THE BELRIV® SYSTEM.

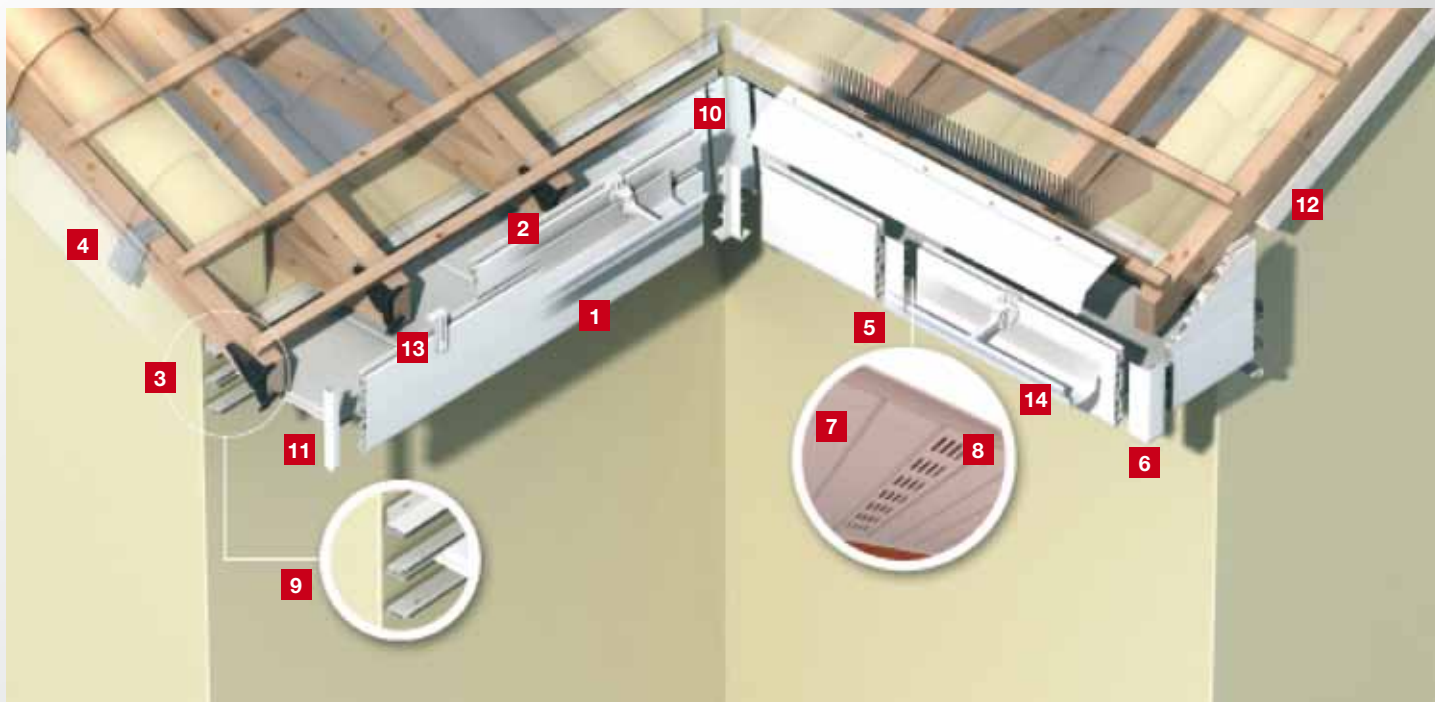

### 1 Fascia boards

2 fascias of 17 and 21cm high. Fitted with a plate allowing the system to expand.

### 2 Extension

The 8cm extension provides 2 extra fascias heights: 17 cm + 8 cm = 25 cm 21 cm + 8 cm = 29 cm.

### 4 Metal plate

2-part system for different header fascia configurations.

### 5 Joints

Multiple-height joints: 17, 21, 25 and 29cm; double for 2 heights: 2 x 17 et 2 x 21cm.

### 6 Corner joint

Inner and outer corner joints of several heights: 17, 21, 25 and 29cm; double for 2 heights: 2 x 17 et 2 x 21cm.

### 7 Hollow soffit

Traditional or modern panel soffit to face eaves at the points of drainpipes and headers, fastened by slotting together.

### 8 Soffit ventilator

Profile to provide eave ventilation. The ventilation surface is 77cm<sup>2</sup>/ml. Its male/female assembly is the same as a soffit and it has a perforated cleat to fasten it to a batten.

### 9 Wall-mounted trim

3 types of profiles for different configurations. Can be fastened to battens, brickwork or timbers.

### 10 Folding "H" trim

To joint soffits in inner and outer angle pieces.

### 11 "Box End" trim

To clad fascia at the bottom header.

### 12 Bargeboard trim

To clad a header rafter without overhang.

### 13 Gutter hook support

The gutter hook support clips to the top of the fascia. It can be used to fit all Nicoll gutter hooks.

### 14 Guttering

All the Nicoll guttering systems can be used with the Belriv® system.



## THE NICOLL EXTRA

### 3 Universal plate

Universal for all fascia heights. It is invisible, designed for mounting fascias on timbers and allows for expansion of the entire system.

# Cladding for eaves

Belriv® system, complete fascias and soffits system

Description	Grey	White	Sand	Brown	Black
-------------	------	-------	------	-------	-------

## CELLULAR FASCIA BOARDS



Height 17 cm	<b>AB174</b>	<b>AB174B</b>	<b>AB174S</b>	<b>AB174M</b>	<b>AB174N</b>
Height 21 cm	<b>AB214</b>	<b>AB174B</b>	<b>AB174S</b>	<b>AB174M</b>	<b>AB174N</b>
Extension 8 cm	<b>ABR84</b>	<b>ABR84B</b>	<b>ABR84S</b>	<b>ABR84M</b>	<b>ABR84N</b>

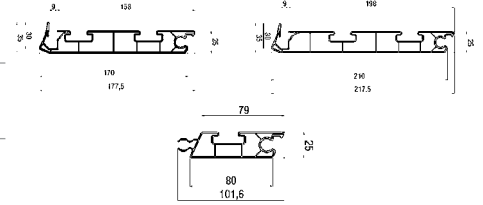

## FASCIA PLATES



Universal plate	<b>APLAQ</b>				
Metal plate	<b>APRIV</b>				
Metal plate for concrete cornice	<b>APCOR</b>				

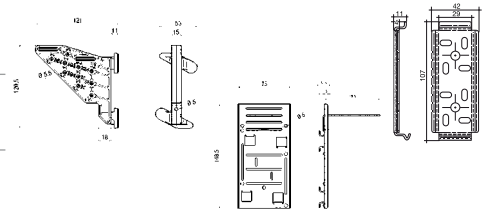

## UNIVERSAL JOINTS, INSIDE AND OUTER CORNER JOINTS



Joint	<b>AJ</b>	<b>AJB</b>	<b>AJS</b>	<b>AJM</b>	<b>AJN</b>
90° outer corner joint	<b>AAE</b>	<b>AAEB</b>	<b>AAES</b>	<b>AAEM</b>	<b>AAEN</b>
90° inner corner joint	<b>AAI</b>	<b>AAIB</b>	<b>AAIS</b>	<b>AAIM</b>	<b>AAIN</b>
135° outer corner joint	<b>AAE135</b>	<b>AAE135B</b>	<b>AAE135S</b>	<b>AAE135M</b>	<b>AAE135N</b>
135° inner corner joint	<b>AAI135</b>	<b>AAI135B</b>	<b>AAI135S</b>	<b>AAI135M</b>	<b>AAI135N</b>
30% rise outer corner joint	<b>AAEM30</b>	<b>AAEM30B</b>	<b>AAEM30S</b>	<b>AAEM30M</b>	<b>AAEM30N</b>
Specially made corner joint	Please ask the Sales Department, email: <a href="mailto:tech-com.nicoll@aliaxis.com">tech-com.nicoll@aliaxis.com</a>				

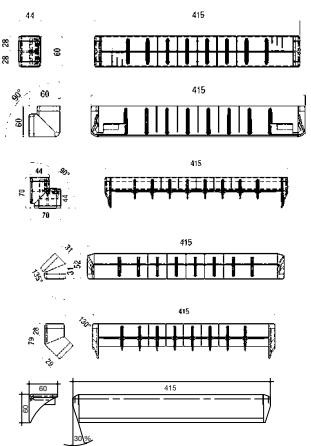

## BRACKET SUPPORTS



Bracket support	<b>ASC</b>	<b>ASCB</b>	<b>ASCS</b>	<b>ASCM</b>	<b>ASCN</b>
Mounted bracket support LG 25	<b>ASC25</b>	<b>ASC25B</b>	<b>ASC25S</b>	<b>ASC25M</b>	<b>ASC25N</b>
Invisible mounted bracket support LG 25	<b>ASCBH25</b>	<b>ASCBH25B</b>	<b>ASCBH25S</b>	<b>ASCBH25M</b>	<b>ASCBH25N</b>
Mounted bracket support LG 29		<b>ASC29B</b>	<b>ASC29S</b>	<b>ASC29M</b>	
Invisible bracket support LG 29		<b>ASCBH29B</b>	<b>ASCBH29S</b>	<b>ASCBH29M</b>	
Mounted bracket support LG33	<b>ASC33</b>	<b>ASC33B</b>	<b>ASC33S</b>	<b>ASC33M</b>	
Mounted bracket support LG28		<b>ASC28B</b>	<b>ASC28S</b>	<b>ASC33M</b>	<b>ASC33N</b>
Mounted bracket support LG38		<b>ASC38B</b>	<b>ASC38S</b>	<b>ASC38M</b>	<b>ASC38N</b>
Mounted bracket support LG30		<b>ASC30B</b>	<b>ASC30S</b>	<b>ASC30M</b>	

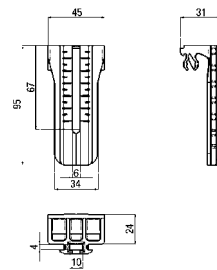

Bracket sizes are listed in the Nicoll Gutter and Roof Accessories Guide.



# Assembly

## 1. Fitting and fastening the fascia board

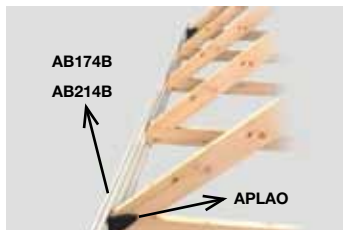

### Fastening the end plates:

- Mount the 2 plates onto the fascia.
- Fasten them to the timbers being careful to keep the fascia in the right position in relation to the roof.
- If the timbers are poorly aligned, stretch a twine from end to end.

## 2. Reversible plate

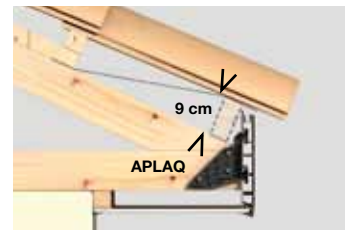
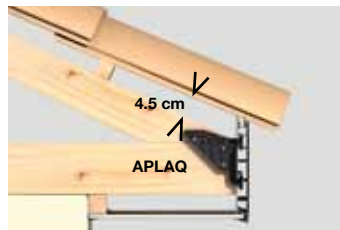

- The plate is reversible: it takes a supporting batten of up to 9 cm (for trusses 0.90 m apart) and counter-battens for roof boarding films.

## 3. Fastening the plate to the support



- The plate is fitted with a 1/4 turn.
- After the 1/4 turn, slide the plate against the support.
- Fit the plate with at least 3 VBA Ø 4 screws, length 40 mm. The holes are oblong to place the fascia correctly before finally clamping it at the 3rd fastening point.

## 4. Fascias of 25, 29cm high or more



- 25 cm fascia board:  
17 cm fascia board + 8 cm extension
- 25 cm fascia board:  
21 cm fascia board + 8 cm extension

## 5. Joining 2 fascias



Cut the joint to match the cutting marks for the height of fascia used.

- Left side of joint: abut the fascia without gluing.
- Right side of joint: position the end of the fascia opposite the ambient temperature mark.

## 6. Fastening the connecting plates



- Fasten a plate to each timber. If the fascia does not have to bear the load of the last row of tiles, the maximum distance between 2 plates is 1 metre.
- If the fascia is load-bearing, see page 9 for the maximum distance between timbers or trusses.

## 7. Expansion control



- Make a fixed point on the plate in the middle of the fascia by screwing the centre plate into the fascia.
- The fixed point on the plate in the middle of the fascia will allow expansion to be evenly spread.



## **BELRIV® TRADI** **Roof fascia and soffit**

Belriv® Tradi, a perfect finish for new and renovated buildings.

Specially developed to adapt to all architectural styles, **Belriv® Tradi** is a highly effective system for complete fascia and protection of eaves. It is discreet and rigid with a unique finish allowing it to blend into any type of building front.

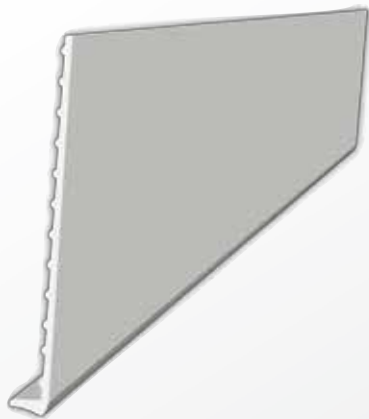

### **ADVANTAGES**

- Nail-on system in cellular PVC.
- No need for maintenance, paint or protective coating.
- 3 different thicknesses: 7mm, 15mm and 18mm.
- Quick and easy to fit.
- Excellent UV resistance for long-lasting colours.
- Frost and bad weather resistance.
- 10-year warranty.
- Adapts to different types of timbers.
- 100% recyclable material.







### 7 MM FASCIA BOARD

The fascia is mounted by nailing it to an existing or new wood counter-fascia. It clads the wood counter-fascia which supports the last row of tiles.

#### Characteristics:

- Overlap 35 mm.
- Fascia heights available: 10 cm, 15 cm, 17.5 cm, 20 cm, 22.5 cm, 25 cm, 30 cm.
- 40 cm double fascia for side cladding.



Special "teardrop" design

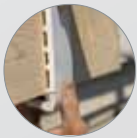

Back embossed to ventilate wood counter-fascia



Joints and angle pieces compatible with 7mm and 15mm thicknesses



### 15 MM FASCIA BOARD

The 15mm thickness is designed for nailing straight onto timbers and trusses. This is an ideal solution for both new and renovation building work and does away with the need for a wood counter-fascia.

#### Characteristics:

- Overlap: 35 mm.
- Fascia heights available: 15 cm, 17.5 cm, 20 cm, 22.5 cm, 25 cm.
- 40 cm double fascia for side cladding.

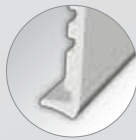

Special "teardrop" design

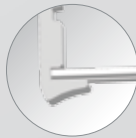

Back groove to hold soffit



Joints and angle pieces compatible with 7mm and 15mm thicknesses



### 18 MM FASCIA BOARD

Designed for certain local requirements, notably for cladding headers or buildings without eaves, the 18mm fascia has a rounded design and a depth overlap.

#### Characteristics:

- Fascia heights available: 15 cm, 17.5 cm, 20 cm, 22.5 cm, 25 cm.
- 40 cm double fascia for side cladding.



Traditional rounded design; overlaps depth of soffit



Quick fitting straight onto timbers or trusses

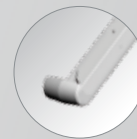

Special joints and angle pieces for 18mm thickness



## THE NICOLL EXTRA

PVC fascias are high density to ensure extreme rigidity for secure fastening to guttering.

# BELRIV® TRADI RANGE

Description	Fascia height (mm)	White	Sand	Cork
-------------	--------------------	-------	------	------

## CELLULAR FASCIA BOARDS

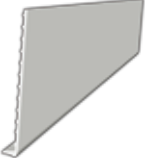
	7mm cellular fascia board	100	C7B104B	C7B104S	
	7mm cellular fascia board	150	C7B154B	C7B154S	
	7mm cellular fascia board	175	C7B1754B	C7B1754S	C7B1754CL
	7mm cellular fascia board	200	C7B204B	C7B204S	C7B204CL
	7mm cellular fascia board	225	C7B2254B	C7B2254S	C7B2254CL
	7mm cellular fascia board	250	C7B254B	C7B254S	
	7mm cellular fascia board	300	C7B304B	C7B304S	
	7mm cellular fascia board	400	C7B404B	C7B404S	

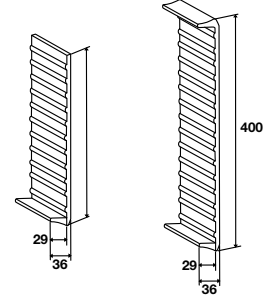

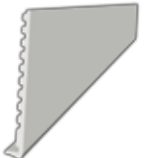

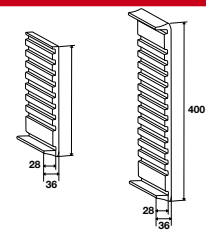

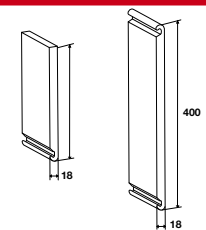

	15mm cellular fascia board	150	C15B154B	C15B154S	
	15mm cellular fascia board	175	C15B1754B	C15B1754S	
	15mm cellular fascia board	200	C15B204B	C15B204S	
	15mm cellular fascia board	225	C15B2254B	C15B2254S	
	15mm cellular fascia board	250	C15B254B	C15B254S	
	15mm cellular fascia board	400	C15B404B	C15B404S	

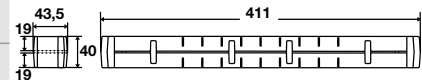

	18mm cellular fascia board	150	C18B154B	C18B154S	
	18mm cellular fascia board	175	C18B1754B	C18B1754S	
	18mm cellular fascia board	200	C18B204B	C18B204S	
	18mm cellular fascia board	225	C18B2254B	C18B2254S	
	18mm cellular fascia board	250	C18B254B	C18B254S	
	18mm cellular fascia board	400	C18B404B	C18B404S	

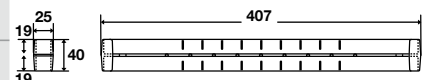

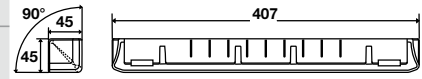
## UNIVERSAL JOINTS, INNER AND OUTER CORNER JOINTS

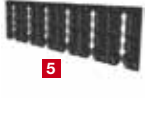
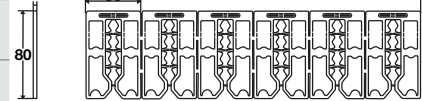
	1 7 and 15mm universal joint		C715JB	C715JS	C715JCL	
	2 18mm universal joint		C18JB	C18JS		
	3 90° universal outer corner joint for 7 and 15mm		C715AEB	C715AES	C715AECL	
	4 90° universal outer corner joint for 18mm		C18AEB	C18AES		
	135° universal outer corner joint for 7 and 15mm		C715AE135B	C715AE135S		
	135° universal outer corner joint for 18mm		C18AE135B	C18AE135S		
	90° universal inner corner joint for 7 and 15mm		C715AIB	C715AIS		
	90° universal inner corner joint for 18mm		C18AIB	C18AIS		
	135° universal inner corner joint for 7 and 15mm		C715AI135B	C715AI135S		
	135° universal inner corner joint for 18mm		C18AI135B	C18AI135S		
	5 Set of 6 compensating wedges 3mm thick		CAL63BELRIV			

## STAINLESS STEEL NAILS

	30mm with plastic head		C130B	C130S	
	40 mm with plastic head		C140B	C140S	C140CL
	65 mm with plastic head		C165B	C165S	C165CL
	Round-head stainless steel nail			C1401	



# Assembly

## Step 1



Position the fascia allowing for the height of the supporting batten and nail to the timbers every 60cm at most.

## Step 2



If the timbers are irregularly aligned, use a compensating wedge (CAL63BELRIV) to fill the gap between the timber and fascia before nailing.

## Step 3



Fasten the finishing profile to hold the soffit in place on the brickwork side.

## Step 4



Clip the soffit into place. Fasten it by nailing the pre-perforated cleat into a batten if the eaves are deep (>60cm).

## Step 5



Install the ventilated soffit in the same way.

## Step 6



Position the joints and corner joints by slotting them between 2 fascias without gluing. Slot one side up to the stop and leave a space of 5mm on the other. Cut the fascia at an angle of 45° to fit the corner joints.

## Step 7



Mark the position of the gutter and screw the hooks into the fascia where the timbers are, no more than 60cm apart.

## Step 8



When the hooks are screwed into the fascia, put the gutter in place.



## THE NICOLL EXTRA

Designed to fill the gap between timber and fascia if the timbers are irregularly aligned, the compensating wedge ensures the entire system is perfectly aligned. It is designed so that several thicknesses can be used together to fill gaps of 3mm, 6mm, 9mm and up to 18mm.





## **NICOLL BELRIV®** **roof soffit**

### Eaves cladding.

Specially developed to adapt to all architectural styles, these roof soffits with a traditional or modern wood panel design are an effective innovative solution for cladding eaves. They simply slot into place and offer perfect cladding of the eaves at the points of drainpipes and headers on any new or renovated building.

#### **ADVANTAGES**

- Traditional or modern design
- No need for maintenance, paint or protective coating; 6 shades including 1 wood finish (Cork)
- Wide range of accessories for fastening and ventilation
- Excellent UV resistance for long-lasting colours
- Frost and bad weather resistance
- 100% recyclable material
- 10-year warranty



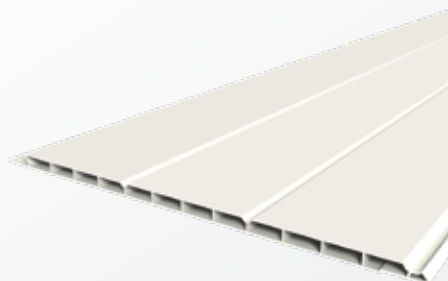

## Modern design

		Soffit
Used for	Eaves, gable edges, canopies, porches, halls, etc.	
Characteristics	<ul style="list-style-type: none"> <li>- 3-panel roof soffit with a modern design</li> <li>- Width 33cm; enhances productivity rates on site (cross fitting)</li> <li>- Perforated cleat for fastening to batten</li> <li>- Locking male part</li> </ul>	
Design and sizes (in mm)		
Assembly	Soffit assembled by male/female clip system	
Shades	<div style="display: flex; gap: 10px;"> <div style="background-color: white; border: 1px solid #ccc; padding: 2px 5px;">White</div> <div style="background-color: #f5deb3; border: 1px solid #ccc; padding: 2px 5px;">Sand</div> <div style="background-color: #8b4513; border: 1px solid #ccc; padding: 2px 5px;">Cork</div> </div>	

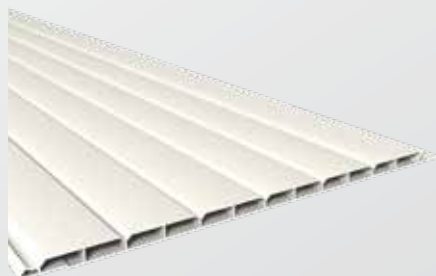

## Traditional design

		Soffit
Used for	Eaves, gable edges, canopies, porches, halls, etc.	
Characteristics	<ul style="list-style-type: none"> <li>- 6-panel roof soffit with a traditional design</li> <li>- Width 30cm</li> <li>- Perforated cleat for fastening to batten</li> <li>- Locking male part</li> </ul>	
Design and sizes (in mm)		
Assembly	Soffit assembled by male/female clip system	
Shades	<div style="display: flex; gap: 10px;"> <div style="background-color: #999; border: 1px solid #ccc; padding: 2px 5px;">Grey</div> <div style="background-color: white; border: 1px solid #ccc; padding: 2px 5px;">White</div> <div style="background-color: #f5deb3; border: 1px solid #ccc; padding: 2px 5px;">Sand</div> <div style="background-color: #4b0000; border: 1px solid #ccc; padding: 2px 5px;">Brown</div> <div style="background-color: black; border: 1px solid #ccc; padding: 2px 5px;">Black</div> </div>	













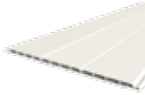

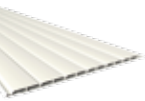
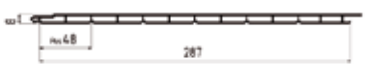

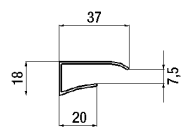
### LE PLUS NICOLL

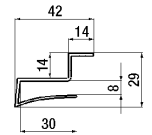
- The Nicoll soffit is designed to resist gale-force winds.
- To prove it, it has been tested in a wind tunnel by the CSTB. The Nicoll soffit withstood winds of up to 216kph. (See CSTB report EN-CAPE 07.100 C-V1)
- To clad deep eaves and courtyard shelters, we recommend screwing the soffit to a batten every 60cm.
- The Nicoll soffit does not require metal clips to fasten it to a batten. The oblong holes on the cleat allow for fastening the soffit straight onto the batten and leave room for expansion.

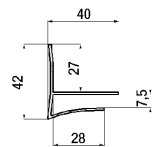

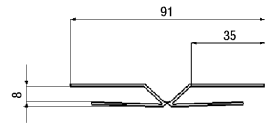
# BELRIV®

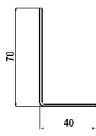
## Soffits and accessories

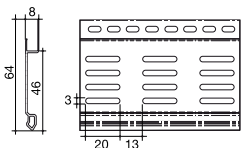
Description	Grey	White	Sand	Brown	Black	Cork	
<b>CELLULAR SOFFIT</b>							
 Modern hollow soffit		PSFA334B	PSFA334S			PSFA304CL	
 Traditional hollow soffit	PSFA304	PSFA304B	PSFA304S	PSFA304M	PSFA304N		
<b>FINISHING TRIMS</b>							
 Narrow overlap trim	PFPR4	PFPR4B	PFPR4S	PFPR4M	PFPR4N		
 Offset Z wide overlap trim	PFGR4	PFGR4B	PFGR4S	PFGR4M	PFGR4N	PFGR4CL	
 Wall-mounted wide overlap trim	PFM4	PFM4B	PFM4S	PFM4M	PFM4N		
 Folding "H"	PHP4	PHP4B	PHP4S	PHP4M	PHP4N	PHP4CL	
 Corner joint trim 70x40	PC744	PC744B	PC744S	PC744M	PC744N		
<b>VENTILATION</b>							
 Air vent profile	PVSF2	PVSF2B	PVSF2S	PVSF2M	PVSF2N		



To see the complete range of Nicoll gutter systems, visit our website: [www.nicoll.fr](http://www.nicoll.fr) or refer to the Nicoll gutter systems technical guide.



# Assembly

## 1. Fitting the wall-mounted trim



The choice of wall profile depends on how the soffit is fitted: horizontally or slanting.

- The fascia is designed to allow for fitting with a maximum slope of 1:1.

## 4. Deep eaves cladding

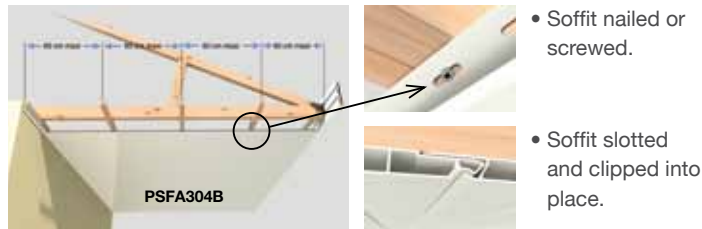

- Soffit nailed or screwed.
- Soffit slotted and clipped into place.
- For eaves deeper than 0.60m, provide midway support.
- For this, screw the soffit to a batten through the oblong holes provided.

## 2. Choice of wall-mounted trim



**Narrow overlap trim (PFPR4B).**

- The profile is fastened to a batten every 40cm. The batten is attached to girders or set into the brickwork.

**Wide overlap trim (PFGR4B).**

- The profile is fastened to the timbers every 60cm at most.

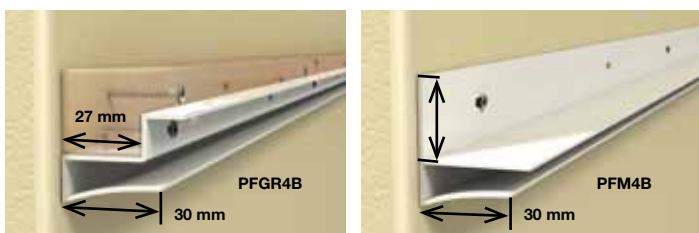

**Large overlap trim (PFGR4B).**

- The profile is fastened to a batten every 40cm. The batten is attached to girders or set into the brickwork.

**Wall-mounted trim (PFPR4B).**

- The trim is fastened to the brickwork every 40cm.

## 5. Deep eaves cladding

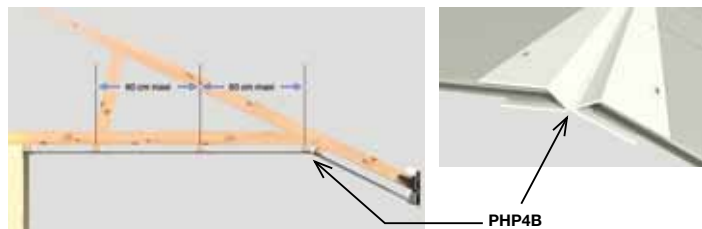

## 6. Fitting an air vent



- The vent has a through section of 77 cm<sup>2</sup>/m.
- The total section (in+out) of the vent openings is defined in the roofing code of practice.
- For roofing where the standards documents (technical evaluation or code of practice) do not specify the vent

section, apply a total section (in+out) under the screen of 1/3000 of the projecting surface (valid for premises with low to medium hygrometry), or an air vent every 36m<sup>2</sup> of the projecting surface.

- The air vent profile is slotted in like the soffit.
- Recessed spotlights can also be fitted to soffits PSFA304B and PSFA334B, in compliance with current standards.

## 3. Fitting the soffit



- Leave a maximum clearance of 1cm when fitting to allow the soffit to slide smoothly.



## THE NICOLL EXTRA

- The Nicoll soffit is designed to resist gale-force winds.
- To prove it, it has been tested in a wind tunnel by the CSTB. The Nicoll soffit withstood winds of up to 216kph. (See CSTB report EN-CAPE 07.100 C-V1)
- To clad deep eaves and courtyard shelters, we recommend screwing the soffit to a batten every 60cm.
- The Nicoll soffit does not require metal clips to fasten it to a batten. The oblong holes on the cleat allow for fastening the soffit straight onto the batten and leave room for expansion.



**BUILDING - SANITARY - ENVIRONMENT**

*NICOLL is ISO 9001v2008 and ISO14001v2004 certified*

Head Office and factories: 37, rue Pierre & Marie Curie - BP 10966 - 49309 CHOLET Cedex // Tel. 02 41 63 73 83 - Fax 02 41 63 73 57

For Requests documentation: [export.nicoll@alixaxis.com](mailto:export.nicoll@alixaxis.com) // Technical enquiries: [tech-com.nicoll@alixaxis.com](mailto:tech-com.nicoll@alixaxis.com)

SAS (business corporation) with a capital of €7,683,431 - 060 200 128 RCS Angers

an **Aliaxis** company