

Kenadrain® slot channels C250

Environment

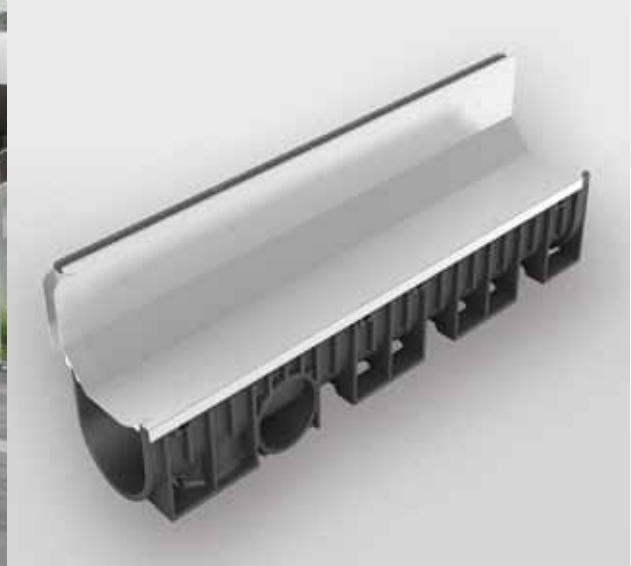

Off-centre stainless steel Kenadrain® 100 mm (5 channel heights) and 150 mm wide slot channels, class C250.

Advantages:

- Appearance: discrete, blends unobtrusively into the urban environment
- Practical: access for inspection and cleaning
- Safe: satisfies accessibility requirements for people with reduced mobility, anti-slip
- Robust: compliant with the NF EN 1433 standard
- Convenient: light, stainless steel slot supplied pre-assembled on channel, optional stainless steel leaf guard
- Durable: high mechanical strength, resistant to most chemicals, corrosion resistant



Kenadrain® slot channels C250

Environment



DESCRIPTION

For discrete, effective drainage of pedestrian streets, plazas, squares or parks, the off-centre Kenadrain® slot channel blends unobtrusively into the urban environment, while ensuring efficient flow thanks to 2 different widths and 5 heights. The stainless steel used to manufacture the slot guarantees the quality and durability of the product. The Kenadrain® slot is therefore suitable for installation in aggressive environments (seaside, saltwater environments, urban settings, etc.)

SLOT CHANNELS:

	DRI102CSE	DRI152CSE	DRIG102CSE	DRIG152CSE
Features	1 m pre-assembled channel with off-centre stainless steel slot C250		1 m pre-assembled channel with stainless steel leaf guard (5x5 mm openings) C250	
Weight	9.66 kg	13.62 kg	10.3 kg	14.2 kg
Width	100	150	100	150
Sides				

100 mm width available in Kenadrain® Park (Height 0) and Kenadrain® Cascade (Height 1, 2, 3, 4) versions. Optional 316 grade stainless steel - Optional stainless steel leaf guard.

ACCESS OPENINGS:

	RDRI102CS	RDRI152CS
Features	50 cm stainless steel access opening C250	
Weight	7.90 kg	11.30 kg
Width	100	150
Sides		

ACCESSORIES:

	Side or vertical taps		Stop end outlets		Sand traps	
Width 100	STDR10	SVDR10	NTDR102	NVDR102	PS100X	PS100V
Diameter Ø	100	110	100	110	125	110
Width 150	SXDR10	SZDR20	NXDR152		PS150Z	
Diameter Ø	125	160	125		160	

INSTALLATION:

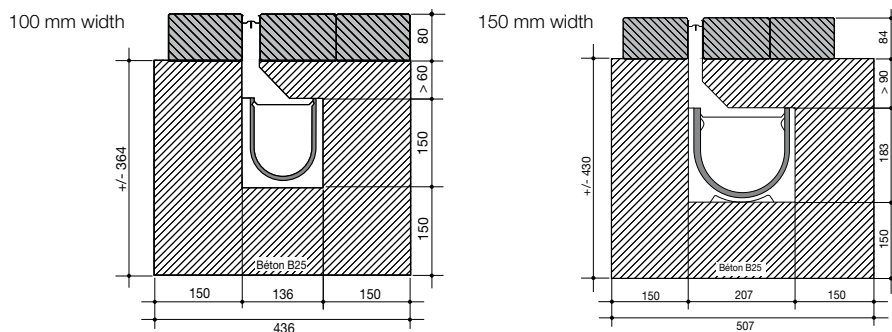

Leaf guard

NICOLL ADVANTAGES

Kenadrain® is synonymous with toughness, performance, lightness (polypropylene) and ease-of-installation.

A patented system:

- The snap-fit system ensures vertical alignment of the channel during male-female interlocking, guaranteeing fast, secure installation.



Photo credits: Nicoll / Non-contractual document



BUILDING - SANITARY - ENVIRONMENT



Head office and industries: 37, rue Pierre et Marie Curie - BP 10966 - 49309 CHOLET Cedex // Tel. +33 (0)2 41 63 73 83 - FAX +33 (0)2 41 63 73 57 - www.nicoll.fr
Email: export.nicoll@alixis.com // Technical information: tech-com.nicoll@alixis.com // SAS (PLC) with a working capital of 7 683 431 euros - 060 200 128 RCS Angers

an OAlixis company